



# BOOKLET 6: WASTEWATER

## TECHNICAL GUIDE FOR NORTHERN HOUSING



TAILORED FOR REMOTE NORTHERN ONTARIO COMMUNITIES





## DISCLAIMER

The information in this publication is based on the most current research available to FNNBOA and has been reviewed by housing industry experts. Readers are advised to evaluate the information, materials and techniques carefully and to consult appropriate professional resources to determine courses of action suitable for their situations. The figures and text are intended as general practice guides only. Project and site-specific factors of climate, cost, geotechnical conditions and architecture must be taken into consideration. Any photographs in this book are for illustration purposes only and may not necessarily represent currently accepted standards. Electronic reproduction of content or this publication is made available for information only and is not an official version of the document. Individuals who download these documents do so at their own risk. FNNBOA will not be responsible for any damage to your computer or any of the information on it.

This document, or any discrete portion of this document (such as a chapter or section) may be reproduced for redistribution, without obtaining the permission of FNNBOA, provided that no changes whatsoever (including translation) are made to the text; that the entire document or discrete part is reproduced; that this copyright notice is included in its entirety in any and all copies of the document or any discrete part of the document; and that no use is made of any part of the document, or the name or logo of the owner of the copyright to endorse or promote any product or service. For any use of this document other than reproduction or for the general reference purposes as set out above, please contact: First Nations National Building Officers Association at [info@fnnboa.ca](mailto:info@fnnboa.ca). For permission, please provide FNNBOA with the following information: Publication's name, year and date of issue.

First Nations National Building Officers Association  
5731 Old Hwy #2, P.O. Box 219  
Shannonville, Ontario K0K 3A0  
[www.fnnboa.ca](http://www.fnnboa.ca)

Tel (613)236-2040  
[info@fnnboa.ca](mailto:info@fnnboa.ca)

1<sup>st</sup> Edition [June 2022]

Provided by FNNBOA under license from the National Research Council of Canada



## The story of wastewater in the north

Most remote communities in the north lack a sewer-pipe network. Wastewater cannot simply flow out of the house in a pipe and connect to a larger sewer-pipe network for the community. It needs to be held in a tank and pumped out on a regular schedule with a sewage-vacuum truck, which then transports and dumps the sewage into a sewage lagoon.

A typical sewage lagoon facility consists of multiple ponds/cells. The wastewater slowly moves from one pond to the next and eventually discharges into a wetland. It provides primary treatment of trucked-in waste through sedimentation and bacterial activity in the warmer summer months.



*A sewage truck dumping into a lagoon*



*A sewage lagoon with a single pond that flows into a wetland*



*A sewage lagoon with multiple ponds*

Septic systems buried in the ground do not work in permafrost, and are challenging in areas without permafrost, due to very deep frost penetration, poor soil conditions, shallow bedrock, or high water tables.

A geotechnical engineer should be consulted if a buried septic tank system is being considered for houses within a community. Similarly, a civil engineer must be involved if a community is considering constructing a wastewater-pipe network.

**This booklet focuses on what wastewater plumbing looks like for a house with a wastewater holding tank that is emptied via vacuum truck pump-out.**



## THE PLUMBING TRADE

This booklet details the work of plumbers. Plumbing work includes:

- Connecting any appliance or fixture that uses water (laundry machines, dishwashers, sinks, showers, tubs, toilets, etc.)
- Layout, assembly, installation, repair, and maintenance of piping for water distribution, wastewater, and drainage.

Plumbing is regulated by the Ontario College of Trades and Apprenticeship Act. It is a compulsory trade, meaning anyone who does plumbing work must be a member of the Ontario College of Trades, which issues certificates of qualification.

Wastewater systems for residential houses fall within the *National Plumbing Code of Canada*, which means that the layout and installation of plumbing for houses is normally done entirely by a plumber. Plumbers have years of training and work experience specifically focused on construction that meets the *National Plumbing Code*.

Even though the wastewater system for a house can be handled entirely by a plumber, the plumbing impacts other aspects of the house, and other aspects of the house impact the plumbing. For example, putting the plumbing vent pipe through the wall instead of the roof makes it easier to seal and will minimize the risk of water and air leaks. Another example is that the wastewater holding tank requires the house to have an enclosed and heated utility space that is below the main floor to avoid needing a sump pump. This additional insulated and heated space needs to be incorporated into the design of the house.

 **This booklet is best used for planning the wastewater plumbing system when the house design drawings are being created, before a plumber is involved. It is a great resource for initial high-level decision making, early-stage budget estimating and planning purposes.**

 **If you are looking to inspect the constructed plumbing, please refer to the *National Plumbing Code*, or obtain the services of a certified plumber.**





## SEPTIC TANK AND FIELD: Gravity System

An alternative to wastewater holding tanks

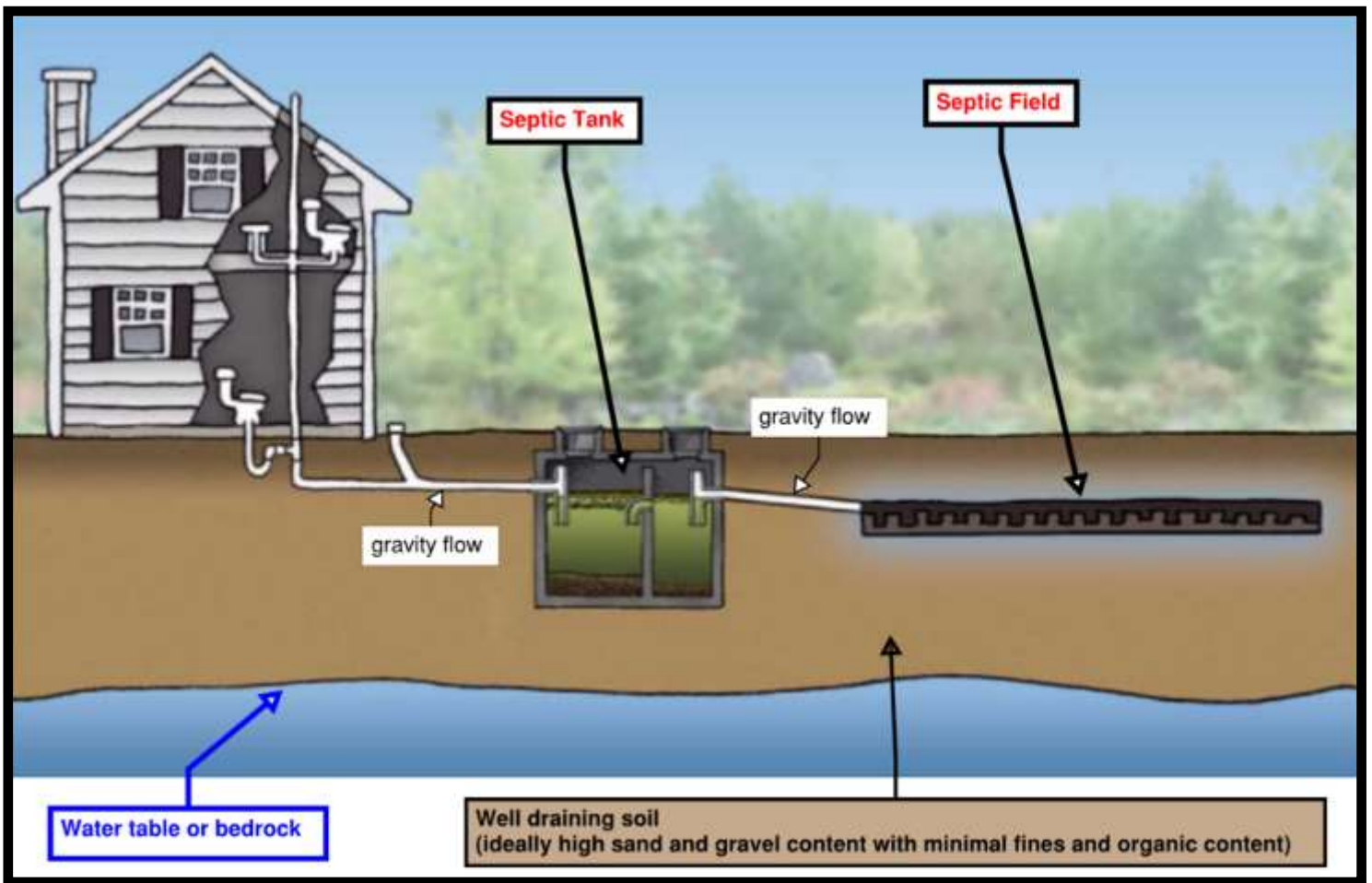

*A typical gravity-flow septic tank and field configuration*

\* Septic systems with pumps also exist, for situations where there is not enough depth of well-draining soil to accommodate slope for gravity flow.



## SEPTIC TANK AND FIELD: Gravity System

Septic tanks and fields are the most common approach to disposing wastewater/sewage in rural regions that don't have a piped municipal sewer system. These systems consist of a septic tank buried in the ground and connected to a septic field with a pipe trenched at a depth below the maximum frost-penetration depth. The tank functions as a place for settlement of solids, so the soil in the septic field does not get clogged with wastewater sludge and sediments, which would lead to backups. Septic tanks with fields work well in locations with deep, well-draining soils and relatively warm climate zones.

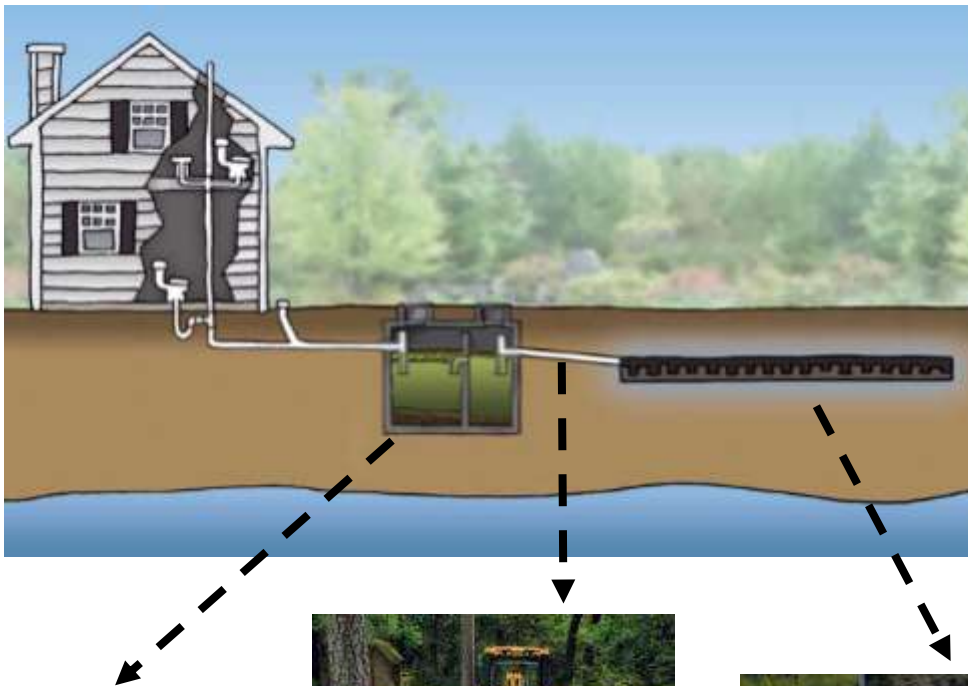

*A septic tank*



*Septic pipe trench between the tank and field*



*A septic-field installation*



## SEPTIC TANK AND FIELD: Gravity System

A septic tank and field approach for wastewater is not suitable for all site conditions and locations. If not properly thought-out in advance, a septic tank and field system is prone to freezing and backing up when used in the north. The typical ground conditions and cold climate of most remote northern communities make septic tanks and fields more problematic and expensive to properly install and maintain.

**! Special measures are needed to prevent septic pipes, tank, and field from freezing.**



*Opening the cover of a septic tank to break up the ice in the septic tank*

*A frozen pipe filled with ice*

**! Septic systems are not feasible where there is permafrost, bedrock near the surface, or a high water table, which is a relatively common condition in many regions of the north.**



*Shallow bedrock typical of the Canadian Shield*





## SEPTIC TANK AND FIELD: Gravity System

The maximum frost depth at the end of winter is typically eight to 12 feet in the boreal forest region. For a septic tank and field system to reliably function, the depth of well-draining soil to the water table or bedrock below must be deeper than the maximum frost depth. To prevent the septic field from freezing, an insulation mat would need to be installed over the field (unless the field is buried deeper than the maximum frost depth).

The insulation mat should be installed over the septic tank, piping, and field, and extend outward horizontally past these elements by the same distance as the frost depth, minus the depth of the element. For example, if the pipe is three feet deep and the maximum frost depth is 10 feet, the insulation mat should extend seven feet horizontally on both sides of the pipe (10 ft - 3 ft = 7 ft). Refer to the foundation booklet section on below-grade basements for a more detailed explanation of the rationale behind the proper insulation, thickness and length.

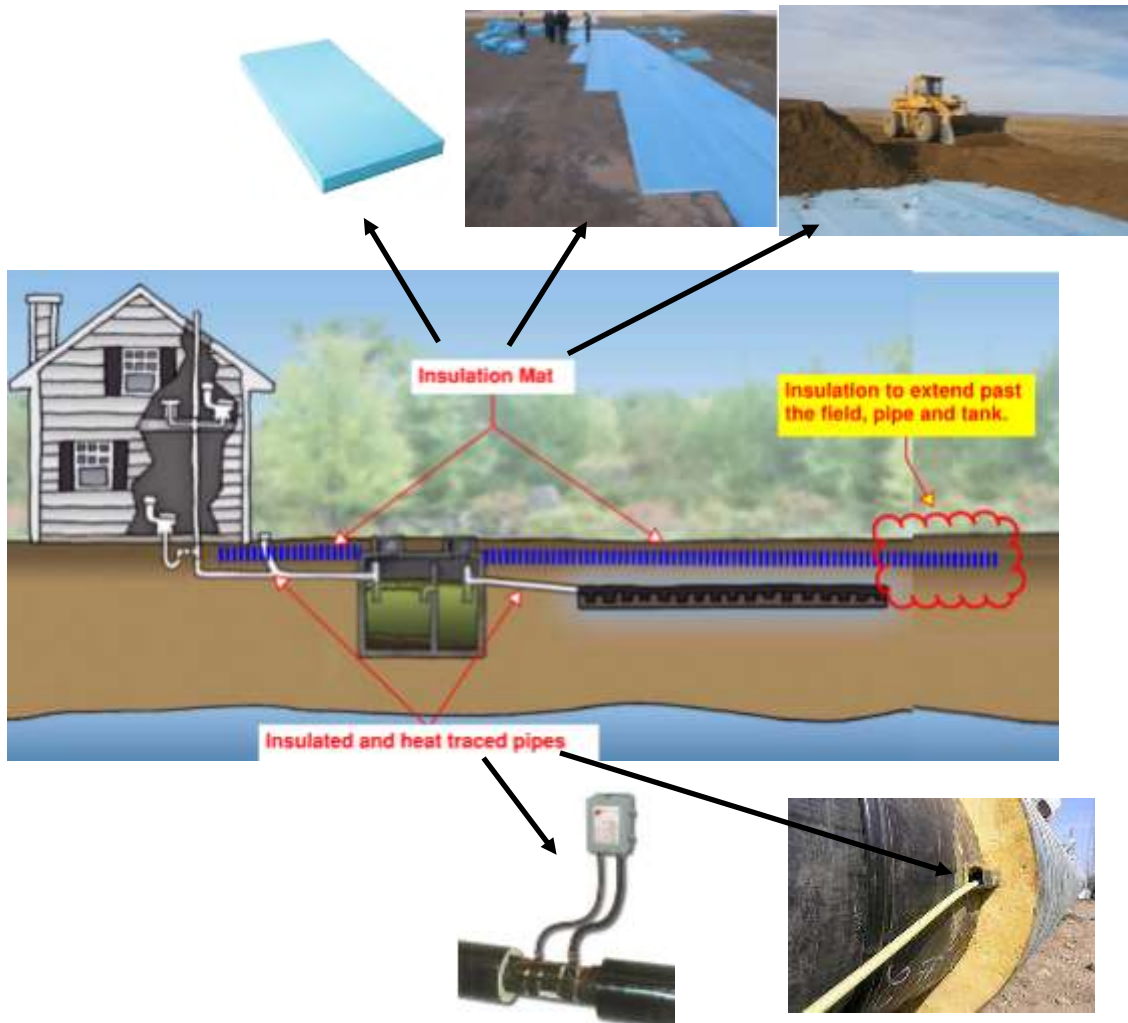

*Insulation mat and insulated and heat-traced pipes*





## SEPTIC TANK AND FIELD: Pump System

**!** If there is insufficient soil depth to slope the connecting pipes from the house to the septic tank and from the tank to the field, to provide gravity flow, a pump can be used to pressurize the pipe and lift the wastewater to the field. However, if the pump fails, the septic system will back up. A septic system that relies on a pump is not recommended for remote northern communities.

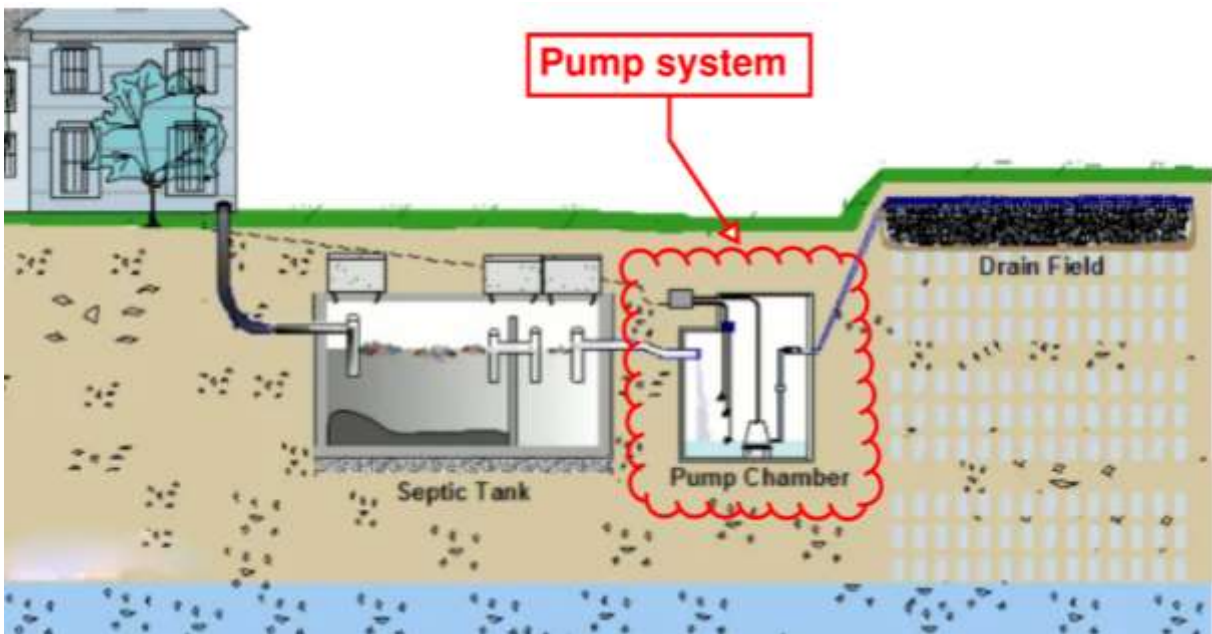

*A septic-tank and field system that relies on a pump*



If a gravity-flow septic system is not feasible, wastewater holding tanks with truck pump-out are recommended (see the following pages of this booklet).

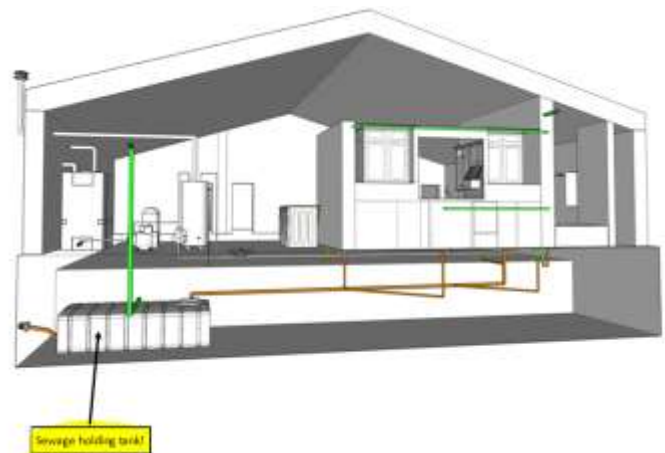

*House with a wastewater holding tank*



## READ THIS BOOKLET IF YOU NEED TO:

1. Include the wastewater plumbing system in plans for the construction of a new house.
2. Understand general components that make up the wastewater plumbing system, and how they are combined to make the complete system.

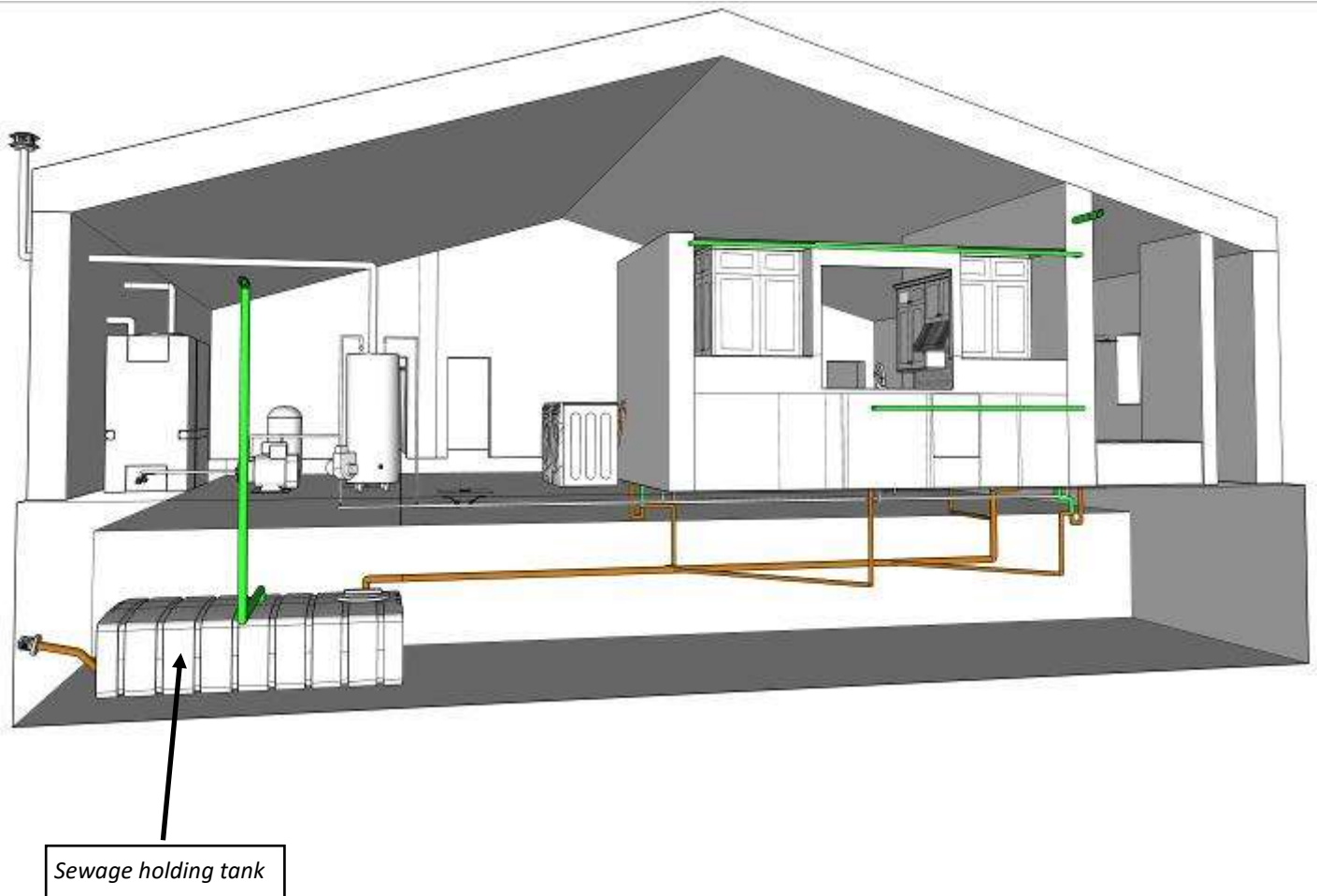

*An overall view of the wastewater plumbing, in brown, in a house with a sewage holding tank*

*Healthy—The ultimate goal is to advise on housing approaches that are most likely to result in healthy living conditions and community well-being (i.e. avoid plumbing problems, last a long time, and minimize maintenance).*



## OVERALL WASTEWATER SYSTEM

A wastewater system for a house that relies on vacuum truck pump-out can broadly be summarized as having five general types of components.

- 1) **Pump-out**
- 2) **Sewage tank**
- 3) **Wastewater pipes**
- 4) **Plumbing traps**
- 5) **Plumbing vent pipes**

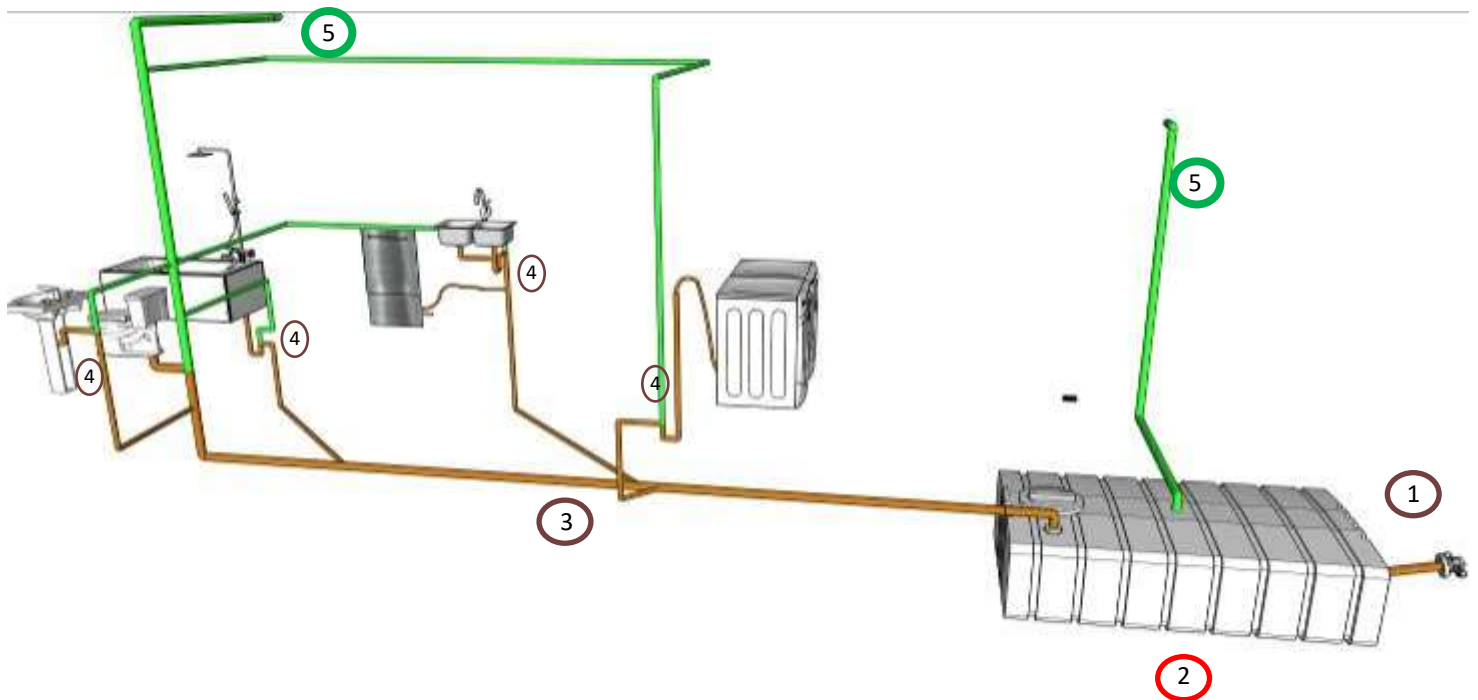

An overall view of the wastewater plumbing system, with the other parts of the house hidden

*Note: Appliances and fixtures that use water, such as showers, are discussed in the freshwater booklet.*





## WASTEWATER SYSTEM COMPONENTS

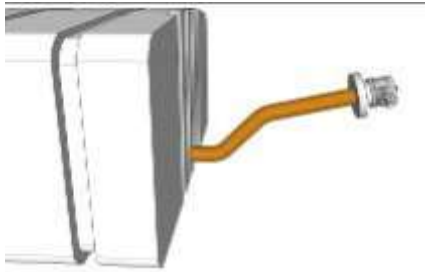

**1) Pump-Out:** For vacuum-truck connection and emptying of sewage tank

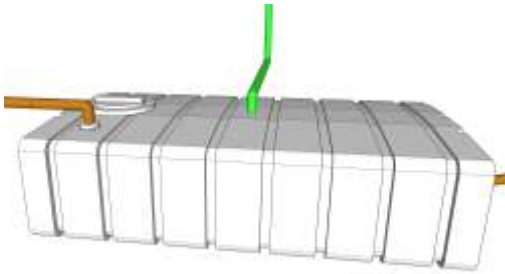

**2) Sewage Holding Tank:** Holds all wastewater until the truck comes

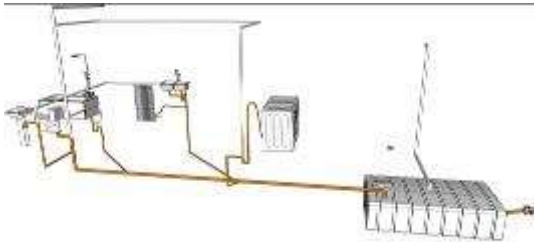

**3) Wastewater Pipes:** Direct wastewater to the sewage tank via gravity flow

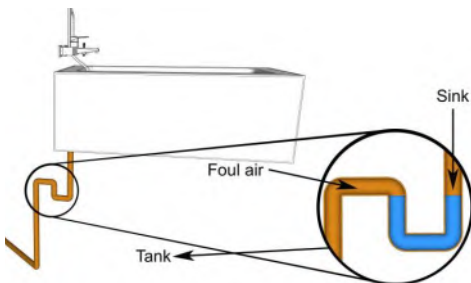

**4) Plumbing Traps:** Stop foul-smelling air in the sewage tank from flowing into the house.

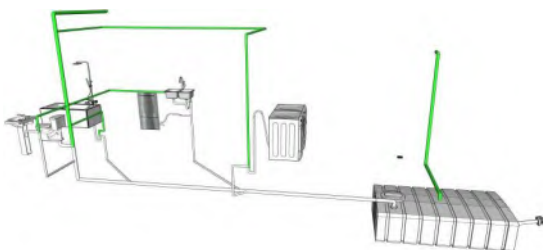

**5) Vent Pipes:** Prevent pressures from forming in the pipes and sewage tank.



## PIPE MATERIAL OPTIONS

Wastewater piping, including its vent piping, is commonly referred to as Drain-Waste-Vent (DWV) piping. Historically, cast-iron pipes were used, but these pipes were prone to corrosion. In modern house construction, plastic DWV pipes generally consist of ABS and/or PVC. Both ABS and PVC are lightweight, inexpensive, strong, and free of corrosion issues. ABS pipe is a bit easier to work with, as joining pipes together is a single-step process that uses adhesive cement alone. PVC pipe requires a two-step process involving a primer and then the adhesive cement. Both materials are well suited to DWV piping in a house.

### ABS Pipe:

- Black in colour
- Slightly easier to work with
- Better able to tolerate extreme cold
- More impact shock-resistant
- More rigid



*ABS pipe*

### PVC

- White in colour
- More flexible
- Better able to tolerate exposure to sunlight



*PVC pipe*

**If in doubt about which material to use for DWV piping, this guide recommends using ABS pipe for its simpler installation and ability to tolerate extreme cold.**



**PUMP-OUT**

For vacuum-truck connection and emptying the sewage tank

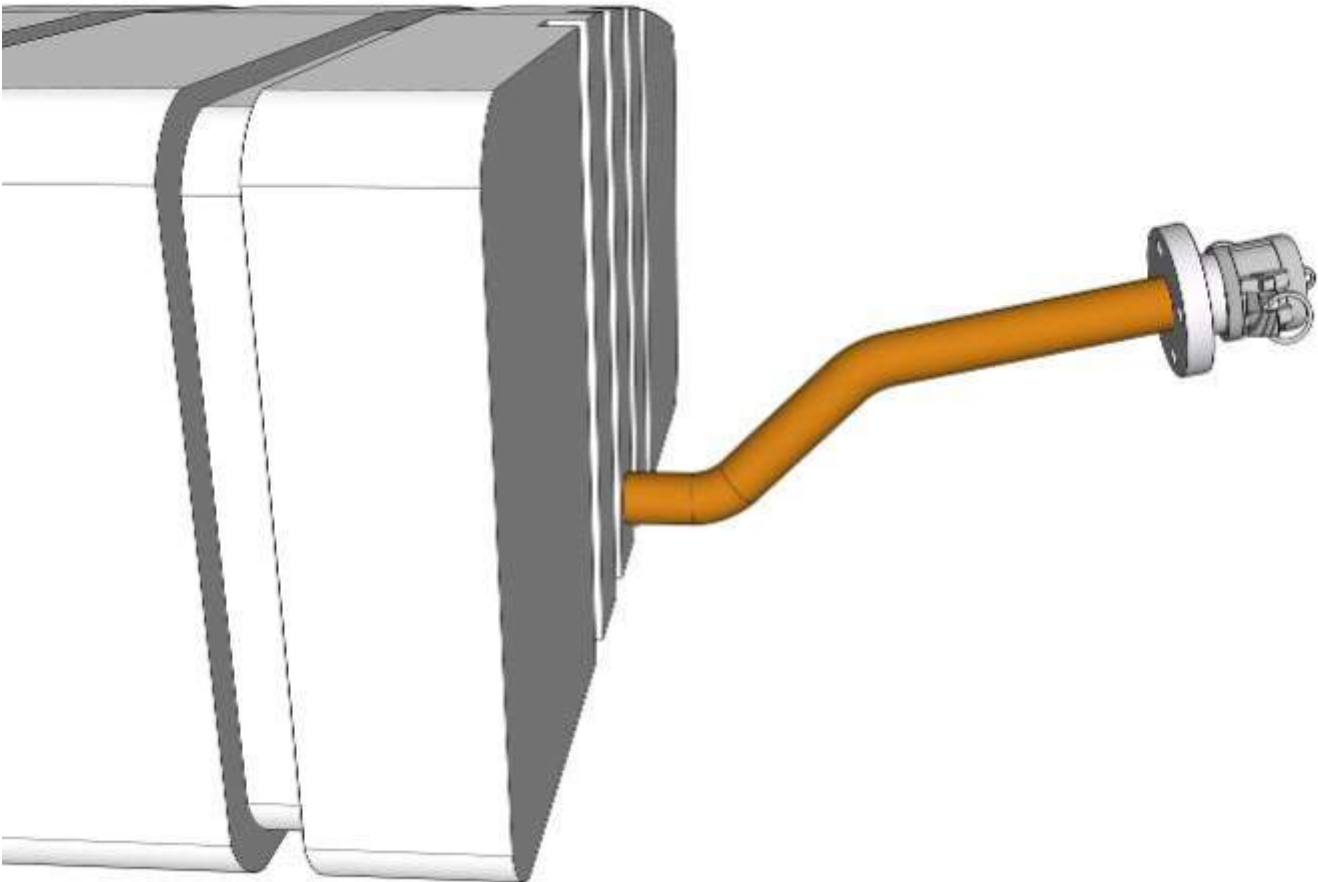

**Sewage holding tank**

*Pump-out pipe shown in brown*





## THE PUMP-OUT CONNECTION

The sewage tank pump-out must be located where it can easily be reached by a vacuum truck and its hose. As the pump-out location can be a source of foul odours, it should be kept away from doors, windows, and air intakes for the house.

The connection fitting must be compatible with the community’s vacuum truck. Typically, a 75-mm diameter fast connection (“camlock”) male fitting at the pump-out that pairs with a 75-mm female camlock fitting is used, but this should be checked with community sewage-disposal personnel.



*The male and female pieces of a camlock connection*

*A typical vacuum hose on a vacuum truck; the threaded end attaches to the truck.*

The camlock “male” fitting at the end of the pump-out needs to be fastened to the wall with a flanged plate fitting, to avoid putting stresses on the pump-out piping. The flange can be used to fasten the pump-out to wood blocking in the wall. A camlock dust cap is needed to cover the end of the pump-out when it is not being used.

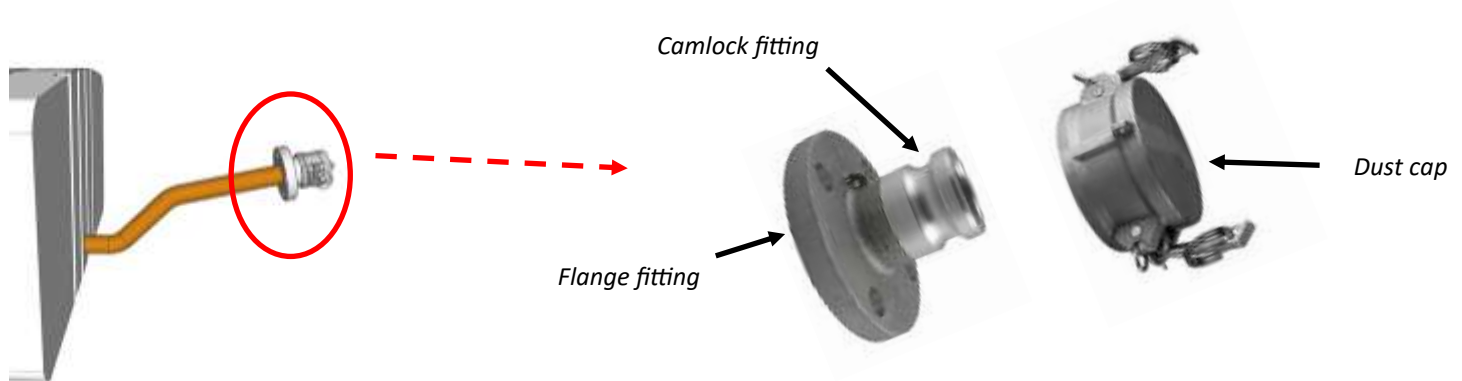

*A camlock connector with a mounting flange, and a dust cap for when it is not being used*



## Continued—THE PUMP-OUT CONNECTION

A short section of copper pipe is recommended for the portion of pipe embedded in the wall, and directly connects to the back of the flange/camlock fittings, as this section of pipe can be exposed to very cold temperatures and forces. The remaining section of piping to the holding tank can be ABS, and connected to the copper pipe with a flexible pipe coupler. This configuration allows the holding tank to be removed for maintenance or replacement without disrupting the through-wall piping and fittings of the pump-out.

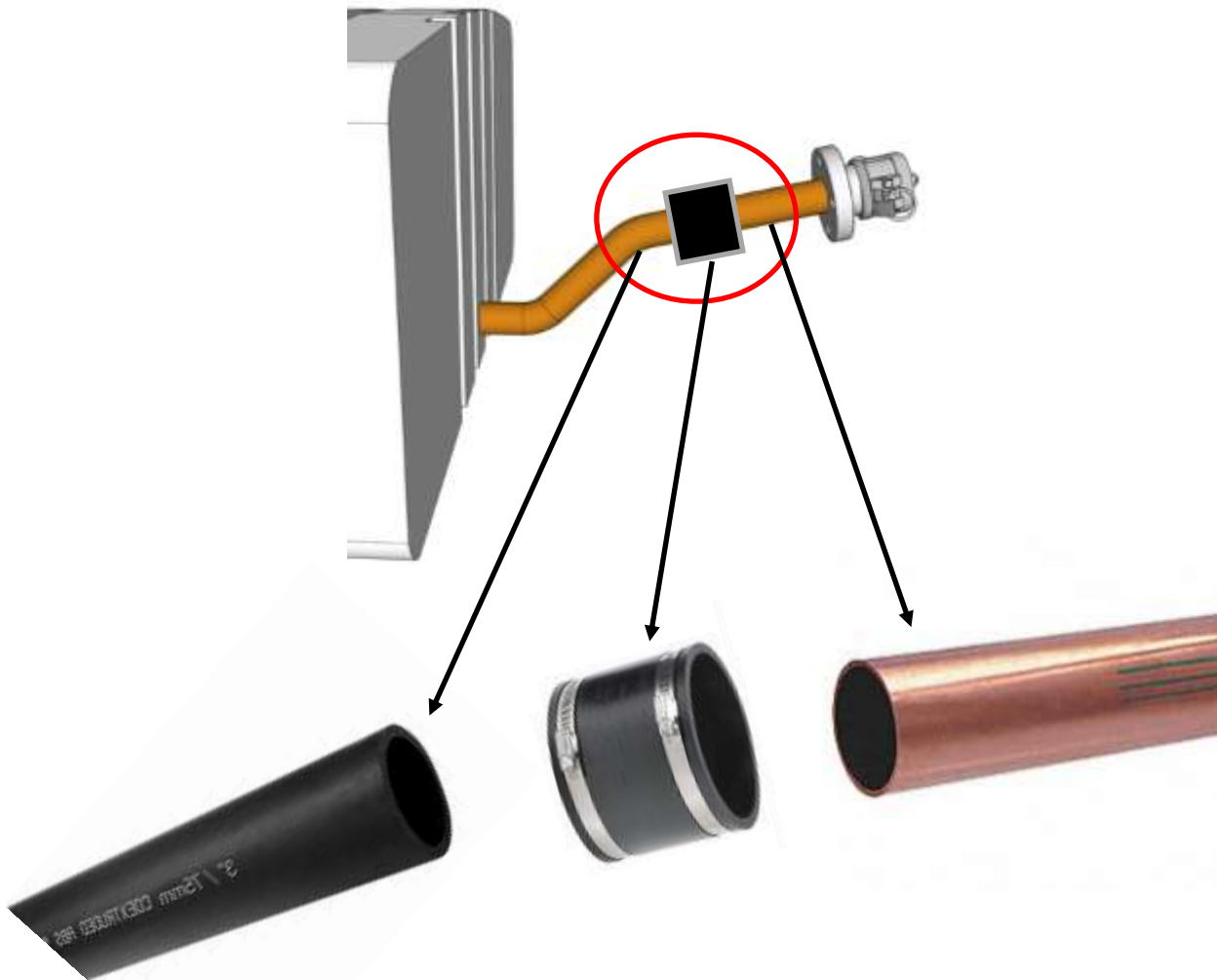

*The components of an ABS to copper pipe connection with a flexible pipe coupler*



## Continued—THE PUMP-OUT CONNECTION

Where the pump-out pipe meets the bottom of the tank, a tank adaptor is needed, and is usually already built into the tank, at the bottom of one of its side walls. It has a rubber gasket that gives the adaptor its seal. A threaded pipe adaptor glued onto the end of the ABS pipe is needed to connect the pump-out pipe.

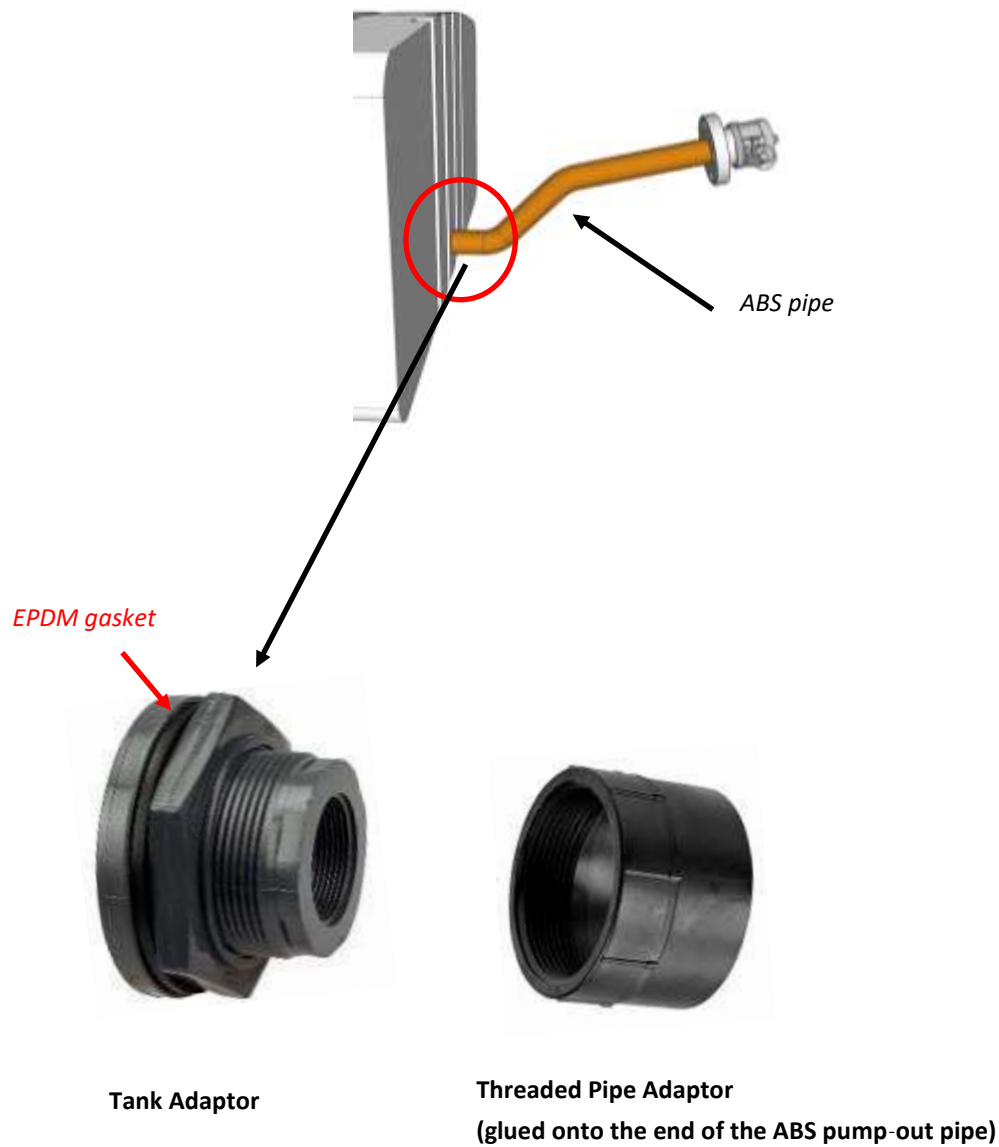

*The components of the pump-out connection to the tank*





## SEWAGE HOLDING TANK

Holds all wastewater until the truck comes

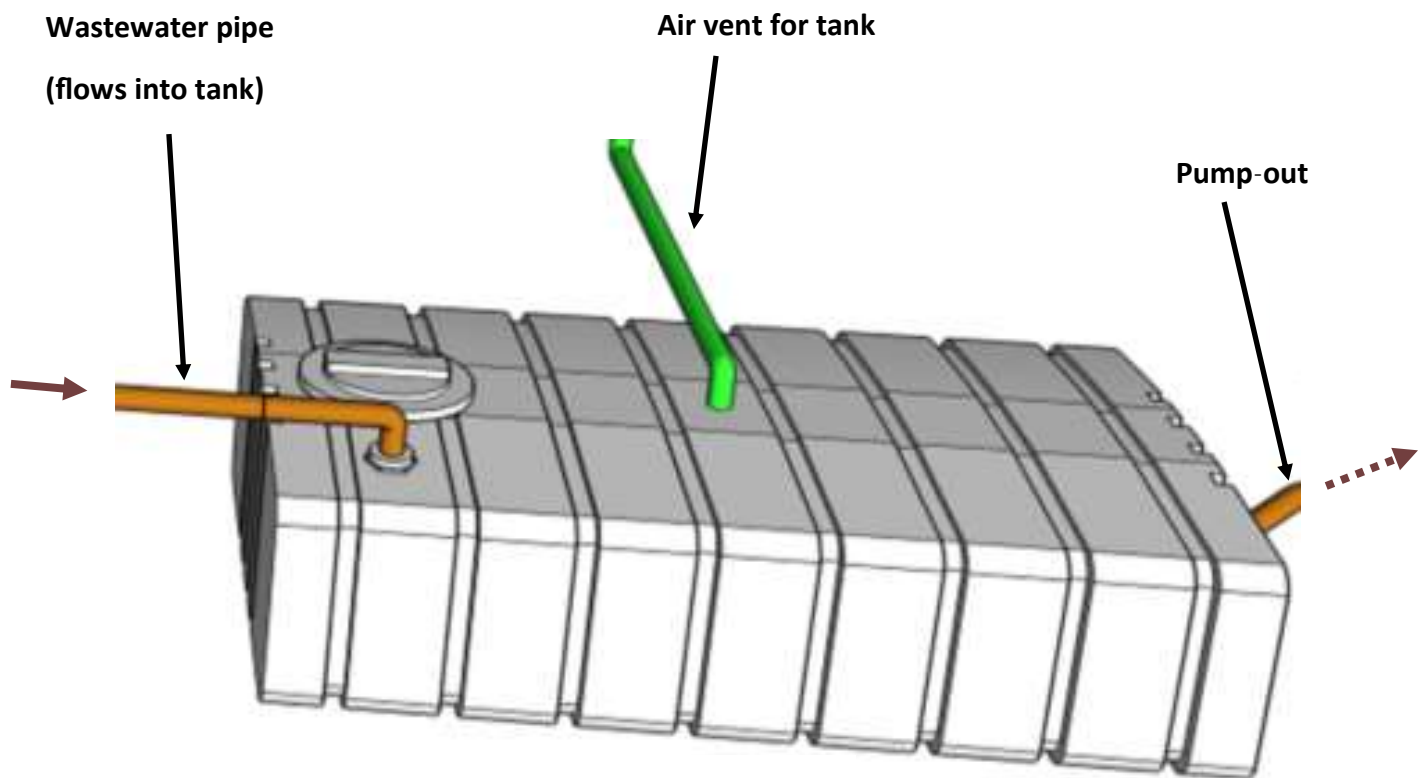

*A low-profile sewage holding tank with the connecting pipes labeled*



## THE SEWAGE HOLDING TANK

Most sewage holding tanks used in residential houses are made of High Density Polyethylene (HDPE). HDPE tanks are durable and strong with very high impact resistance, and are generally the most cost-effective material. Fibreglass tanks, also referred to as Fibre Reinforced Plastic (FRP) are much more expensive, and are better suited for tanks larger than a house would need.

- ✔ It is recommended that the sewage holding tank be **located under the house** so that the wastewater can easily flow into the tank with gravity alone. Low-profile HDPE tanks are readily available, and are ideal for a shallow utility space below a house.



*A low-profile HDPE tank (4,500 litres)*

The location of the sewage tank is critical. If it is not under the house, a pump will be needed to lift the wastewater up into the tank. If a pump is necessary for the plumbing to work, and the power goes out, the wastewater will be at risk of backing up and making a mess. Any failures in the pump will create similar issues.

**A wastewater pump significantly reduces the reliability of the wastewater system, and should be avoided.**

- ⚠ A system with a wastewater sump pump would be located as low as possible in the house. Wastewater would flow into the sump via gravity, and the pump would become activated as it fills. A float inside the sump tips the pump's switch.



*A self-contained wastewater pump*



## Continued—THE SEWAGE HOLDING TANK

The utility space under the house needs to be heated and insulated so the tank and its connecting pipes do not freeze. The floor between the occupied space above and the utility space below can be separated by the floor joists and flooring finish alone. Additional environmental separation layers such as insulation or an air barrier between the utility space and the house space above are not required.

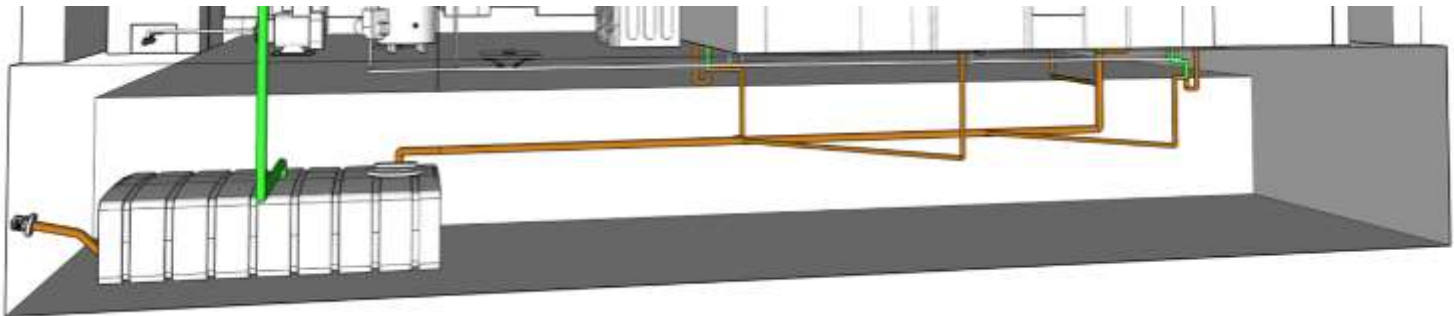

*A utility space under a house for the wastewater holding tank and its connecting piping*

An access opening into the tank is required for inspections, maintenance, and repairs. The access opening must have a watertight and airtight seal. It should also be at least 450 mm in diameter.



**Access Opening**

*A wastewater holding tank and its access opening*





## Continued—THE SEWAGE HOLDING TANK

It is recommended that the utility space under the house extend directly below the utility space on the main floor of the house. In this arrangement, a trap door can be installed in the floor of the upper utility space, directly over the access opening on top of the tank. This will reduce the needed clearance between the floor and the tank.

The utility space should also have a large door or removable panel for easy access into the space for inspections, maintenance, and repairs. The door or panel should be big enough that the tank could be removed and replaced through the opening.



*A utility space under a house with a removable/operable door panel*

The sewage holding tank should hold at least 1.5 times more than the freshwater holding tank. It should also accommodate at least three days of use before needing to be pumped out.

An approximate starting point for sizing the tank is that each person living in a house will produce 150 litres of wastewater per day. If a house is designed for a maximum occupancy of six people, the tank would need to accommodate 900 litres per day. Assuming the tank is pumped out every three days, the tanks would need to hold at least 2,700 litres (714 U.S. gallons). A larger tank will reduce the frequency of having the tank pumped out. For example, a 1,500 U.S. gallon (5,670 L) tank may need to be pumped out only once a week, assuming an occupancy of six people and a maximum 150 litres of wastewater produced by each person in a day.



## Continued—THE SEWAGE HOLDING TANK

### Tank-Level Signaling

A signal that shows when the tank is full is needed to avoid overflowing the tank. A two-stage system that uses float switches is recommended.

- 1) **Stage 1 (warning):** When the wastewater level is about 75 mm from the high-water line of the tank, a float switch connected to a warning light will activate. The warning light should be in the house where it will be easily noticed, so that occupants know to notify the contact for the vacuum truck that the holding tank needs to be emptied.
- 2) **Stage 2 (shut down):** When the wastewater level is about 25 mm from the high-water line of the tank, a float switch connected to a red alarm light will activate on the exterior of the house and near the pump-out location. This float switch should also cut off the power to the pump that pressurizes the freshwater plumbing system so that no more freshwater leading to the drains in the house is released.

Note that the floats will need to be connected to an electromechanical control system that is then connected to the electrical wiring for the warning lights and the pump for the freshwater system.

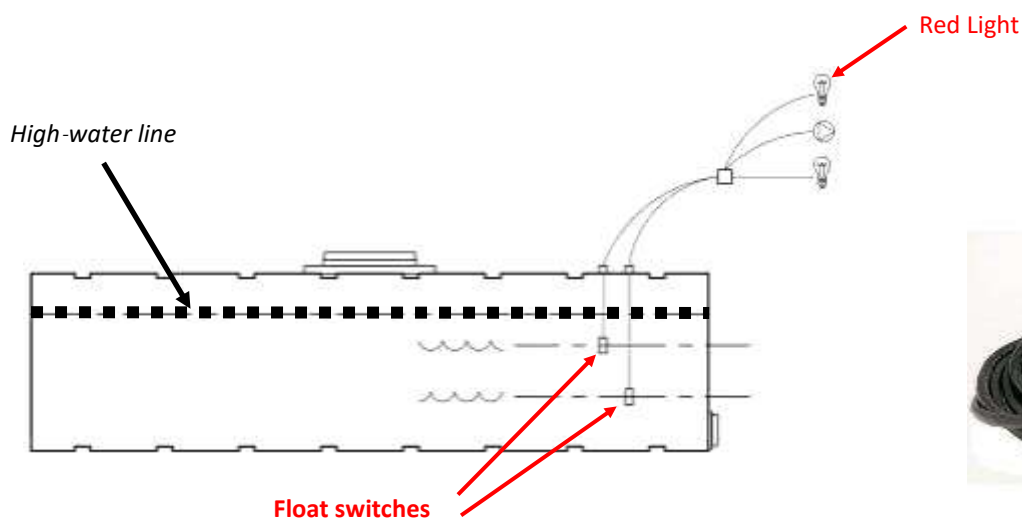

*A concept drawing of the float switches in the tank that signal when the tank is full*

*A typical float switch*



## WASTEWATER PIPES

Direct wastewater to the sewage tank via gravity flow.

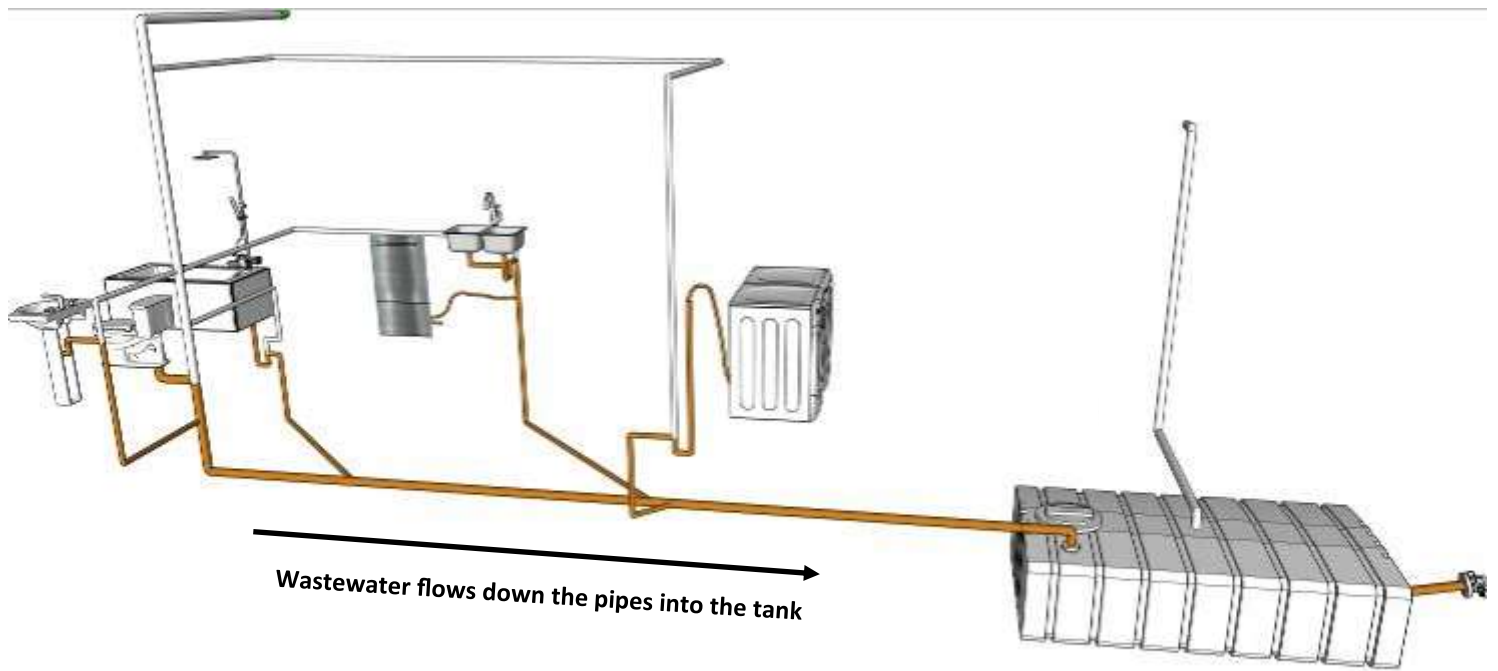

*Wastewater pipes are shown in brown*



## WASTEWATER PIPES

It is recommended that the wastewater pipes extend vertically down through the floor, into a utility space below each water appliance or fixture. This avoids issues with trying to install horizontal pipe within the floor. Once in the utility space below, horizontal piping is needed to bring the water to the sewage tank. These horizontal pipes should ideally have a slope of 1/4" per foot (or one inch per four feet). Support hangers will most likely be required to hang the horizontal pipe from the underside of the floor joists, unless the tank is very close and the horizontal length of pipe is very short.

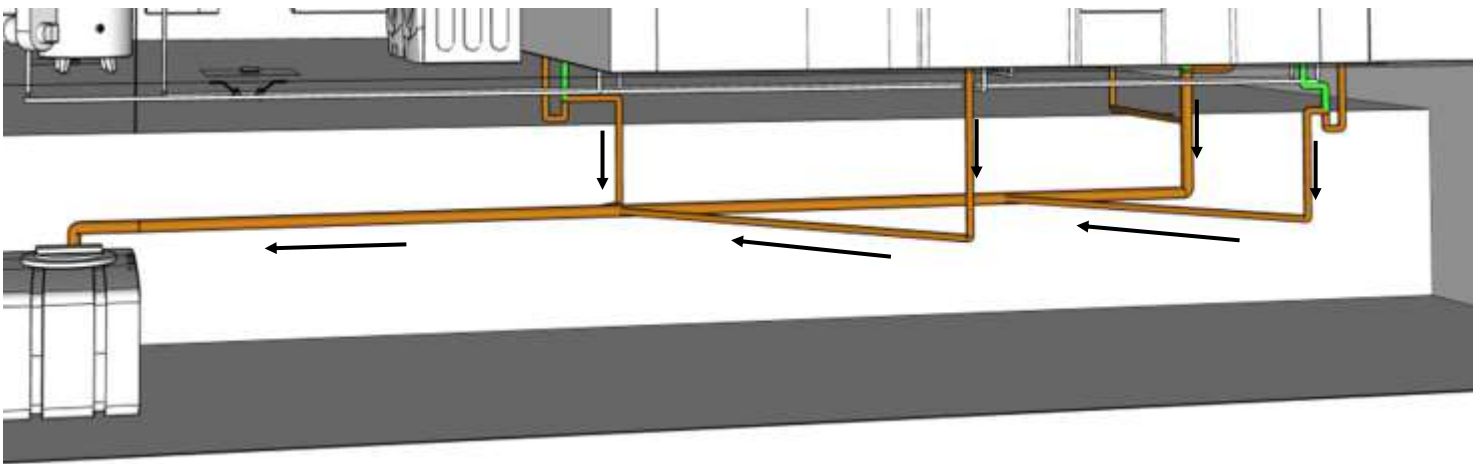

*Vertical piping below each water appliance/fixture, and horizontal piping in the utility space below the floor*



*A horizontal pipe supported by a pipe hanger attached to a floor joist*





## Continued—WASTEWATER PIPES

The main collector pipe that connects to the sewage tank needs to enter at the top of the tank with a water-tight seal. This main collector pipe is typically four inches (100mm) in diameter, and connects directly to the toilet, as the toilet requires a four-inch (100mm) pipe connection. Other water appliances and fixtures, such as sinks, tubs, and washing machines, are typically connected with two-inch (50 mm) or 1.5-inch (38 mm) diameter pipes that join with the main four-inch (100mm) collector pipe.

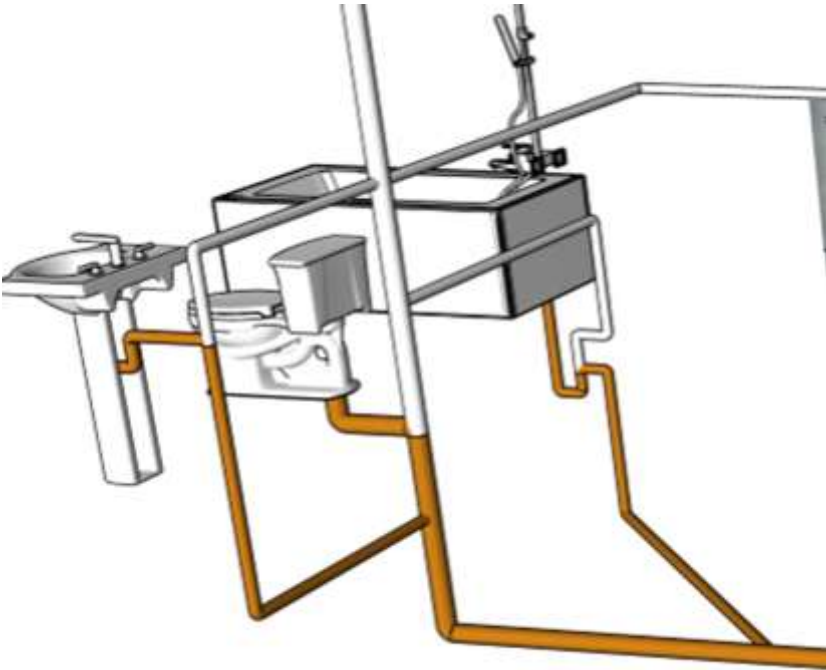

*Four-inch (100mm) main collector pipe connected to the toilet and the sink and tub connected with two-inch (50mm) pipe branches*

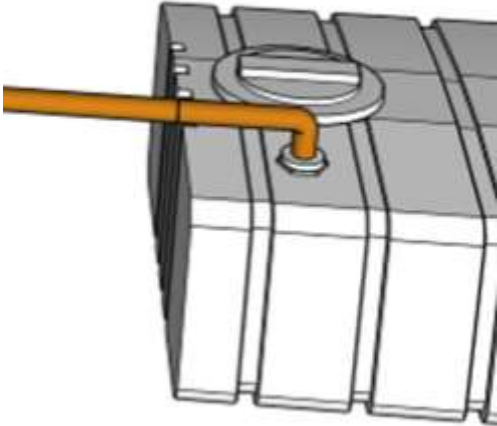

*The main collector pipe connected to the top of the wastewater tank*



## PLUMBING TRAPS

Stop foul-smelling air in the sewage tank from flowing into the house

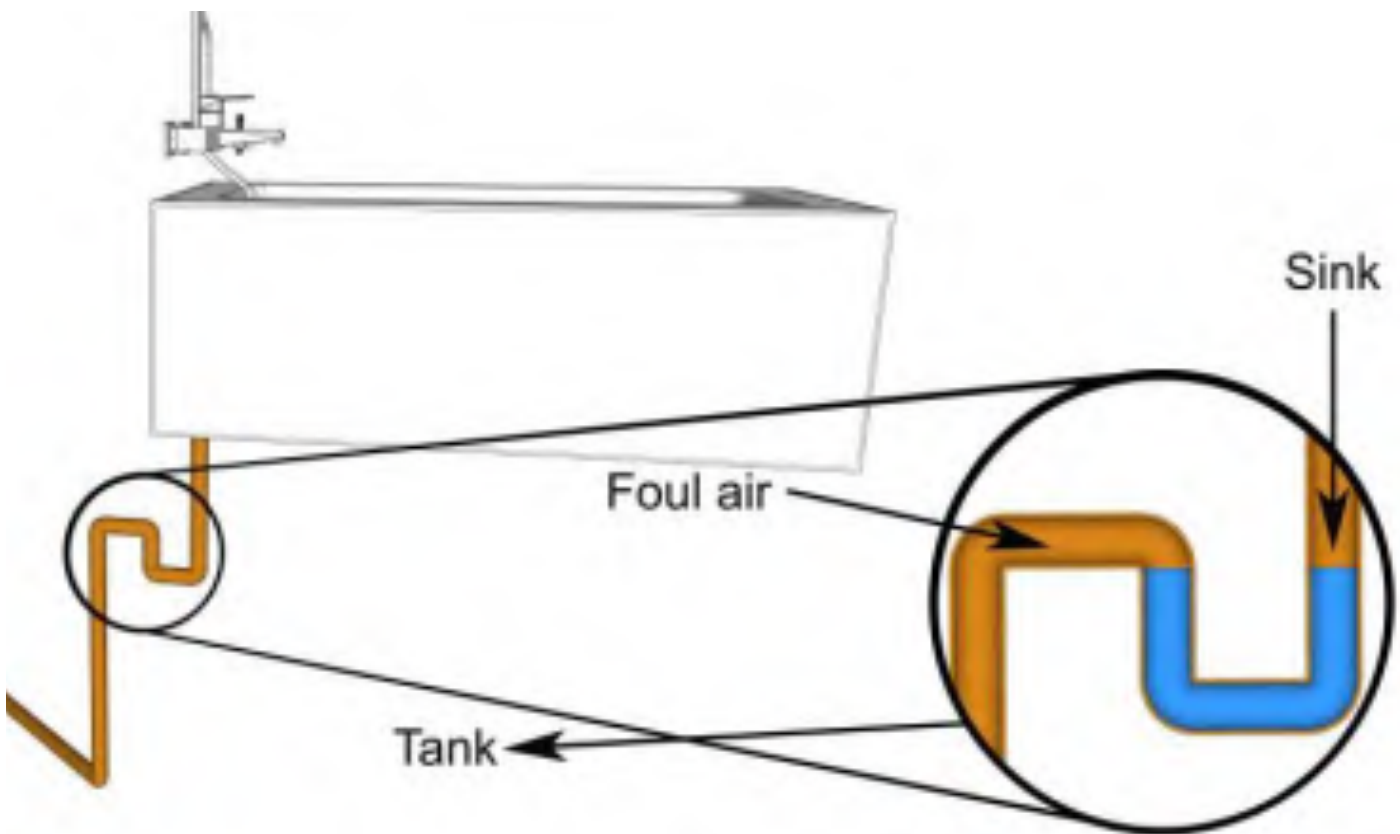

*A plumbing trap below a sink with a zoom view showing how water is trapped in the pipe, stopping odours from reaching the inside of the house*



## PLUMBING TRAPS

Plumbing traps are U-shaped sections of pipe that hold water even when the pipe system is empty. The water in a plumbing trap prevents the air inside the sewage tank from flowing up the pipes and mixing with the air in the house.

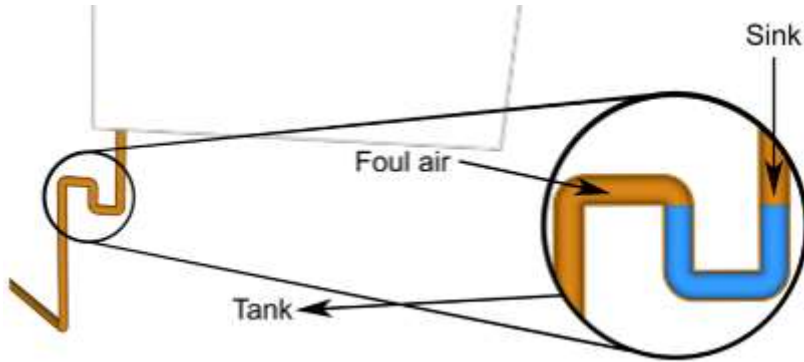

*Concept image showing how a trap works*

*A typical plumbing trap in a house*

**Each water appliance or fixture requires its own plumbing trap. The one exception is the toilet; the bowl filled with water functions as a trap.**

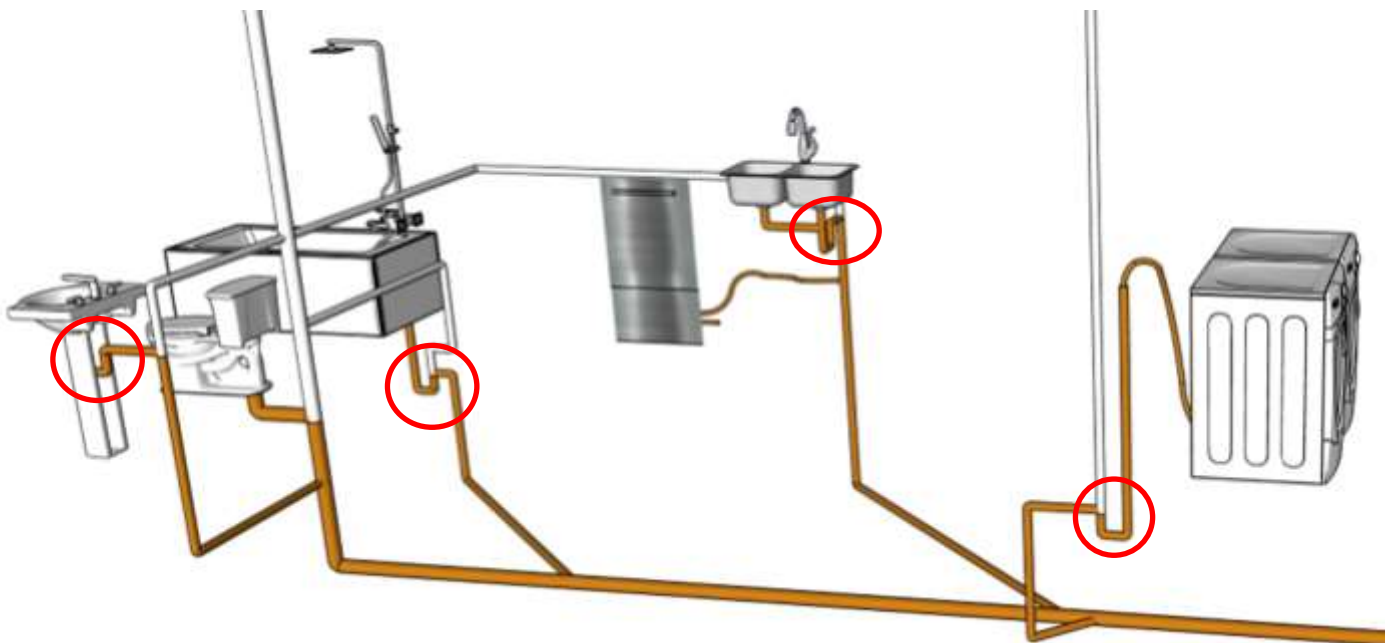

*Each water appliance/fixture with its own trap*



## VENT PIPES

Prevent pressures from forming in the pipes and sewage tank

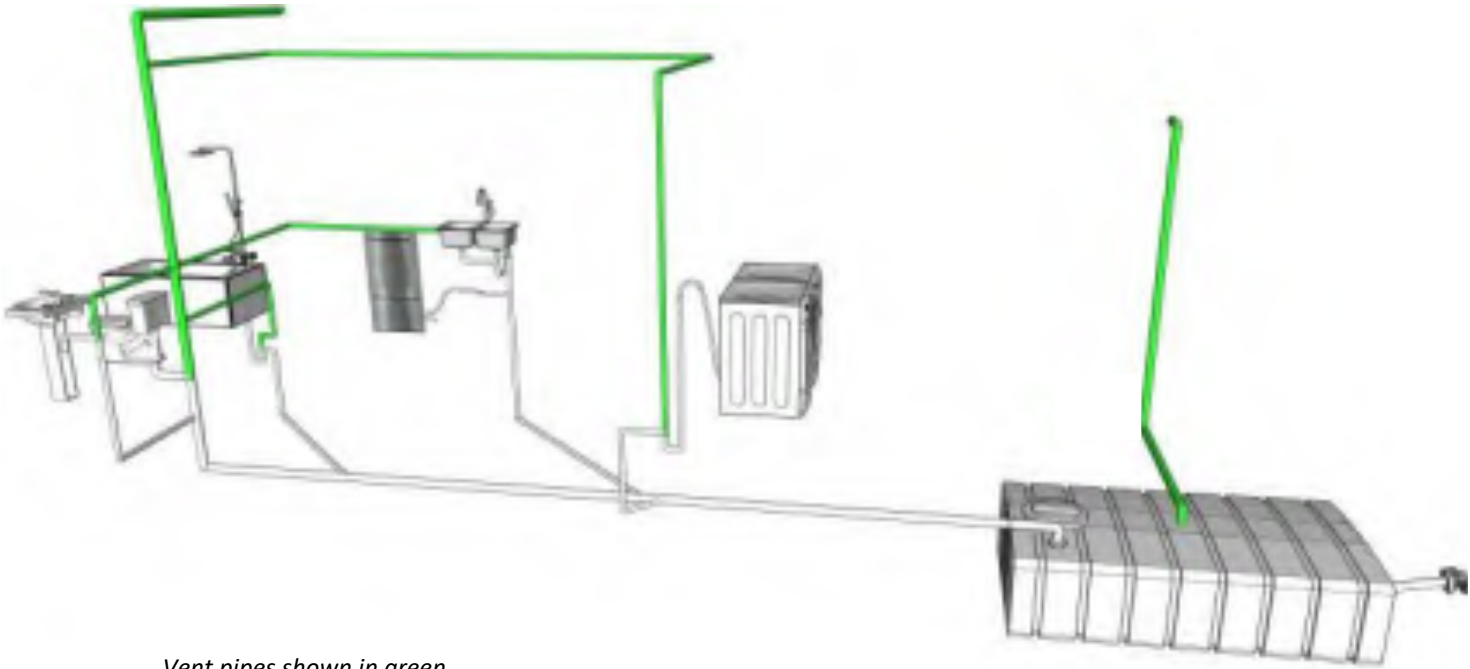

*Vent pipes shown in green*





## VENT PIPES

The wastewater pipes and holding tank both need to be vented to prevent pressures from forming in the pipes or sewage holding tank. A vent pipe is connected to the plumbing system at one end and is open to the outside air at the other end. Vent pipes allow air in the plumbing system to flow out, as wastewater enters the system. Vent pipes also allow outside air to flow into the plumbing system when the wastewater holding tank is being pumped out.

A vent pipe connected to the sewage holding tank also allows air in the tank to leave as the tank fills with wastewater.

Venting the wastewater pipes prevents suction pressures from forming that could siphon water out of the traps. The wastewater pipes are vented with a main vent pipe that extends from the main four-inch (100mm) diameter wastewater pipe.

*Vent pipe for the  
wastewater pipes*

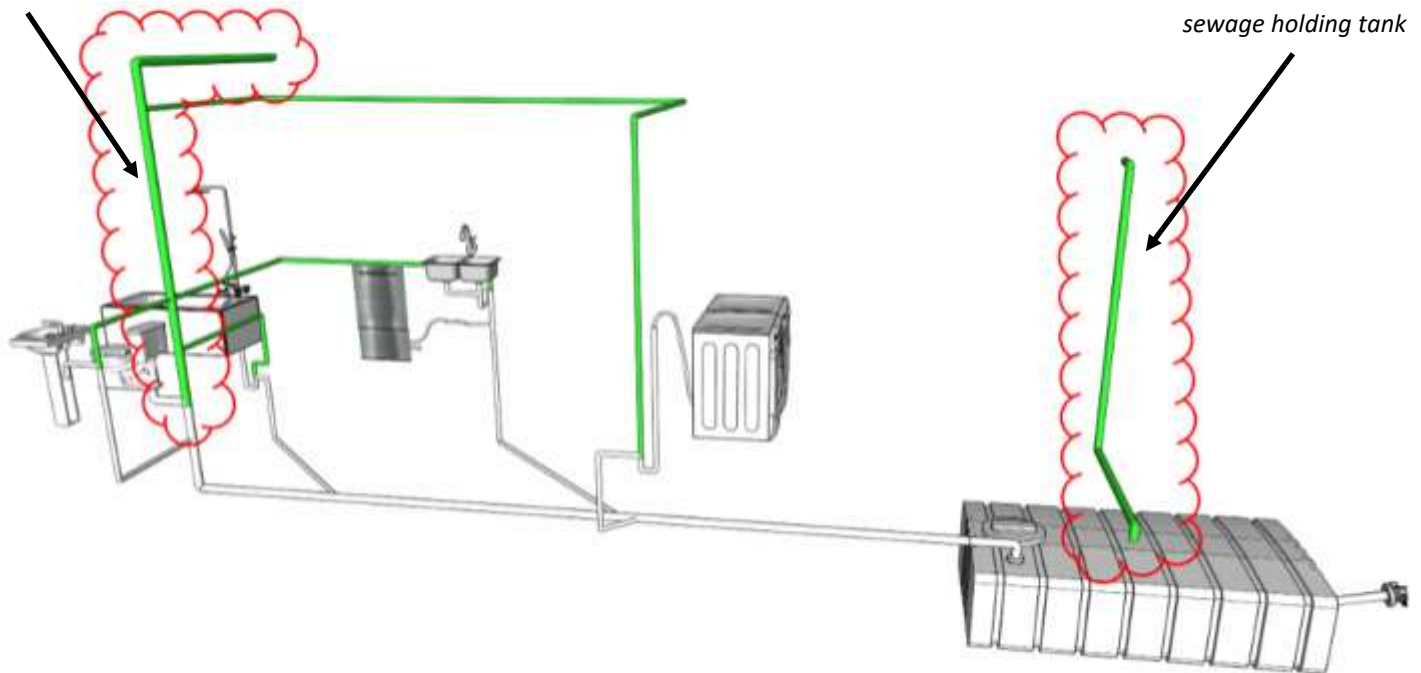

*Vent pipe for the  
sewage holding tank*

*Vent piping shown in green with main vent pipes for the tank and wastewater pipe bubbled in red*



## Continued –VENT PIPES

Each branch of the wastewater piping system also needs to be vented. This is achieved by connecting vent piping to the main vent pipe. The vent pipe connection should be located close to the trap.

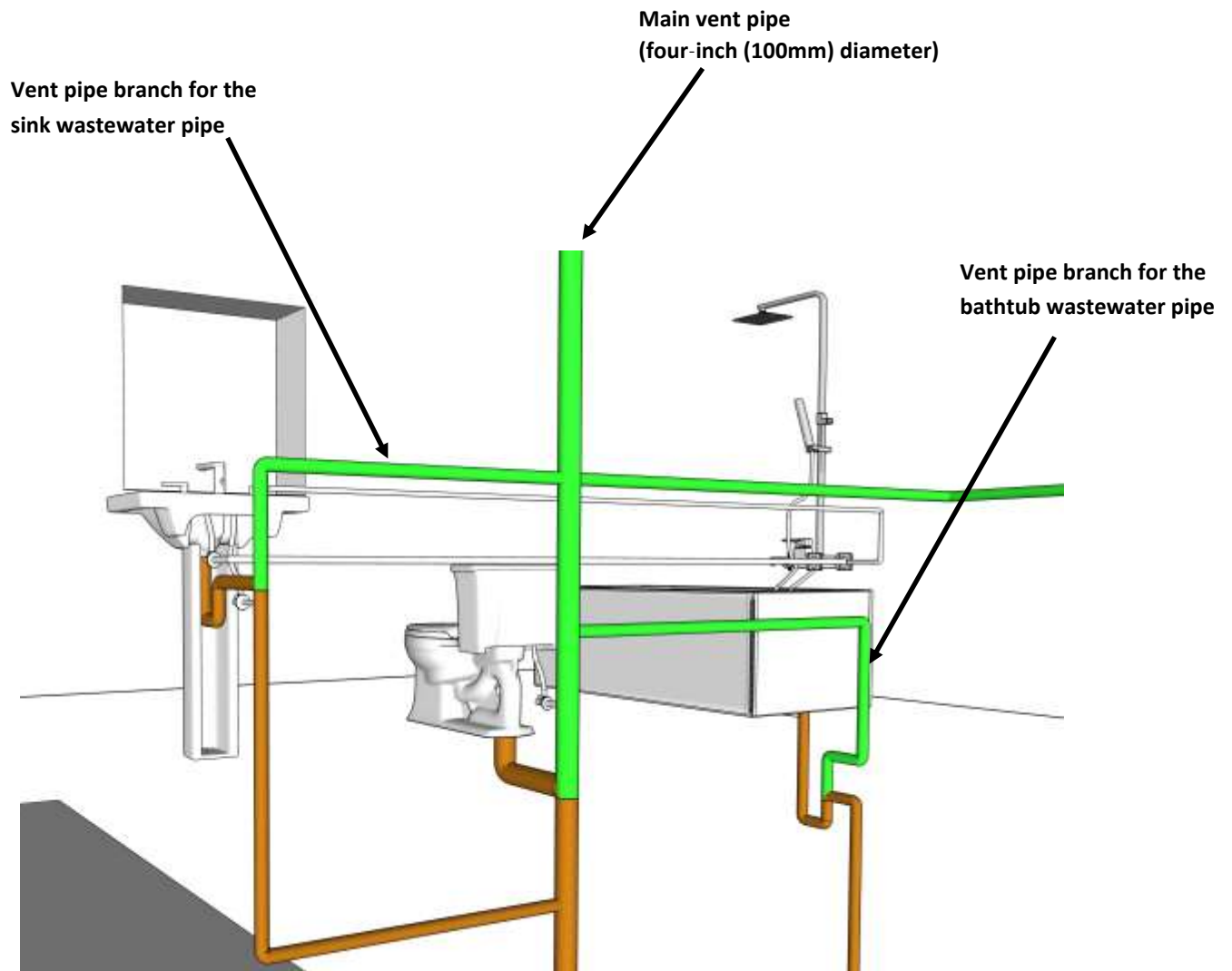

*Branches of vent piping to the main vent pipe that match each of the wastewater pipe branches*



## Continued — VENT PIPES

Ideally, the vent pipe for the holding tank and the vent pipe for the wastewater piping will be connected so that only one vent penetration is needed to the outside. If there are two penetrations on different sides of the house, wind pressures could result in cold air blowing through the plumbing, which would chill the plumbing system.

The plumbing vent should be heat-traced and insulated where it penetrates the wall so that it does not get blocked with ice during the winter months.

The plumbing vent should penetrate a wall instead of the roof to avoid water-leakage and snow-drifting issues. Vent penetration in the wall should be located away from windows, doors, and air intakes.



*A plumbing vent on a roof blocked with ice*

Plumbing vent penetrations through the roof should be avoided as the risk of water leakage is greater with roof penetrations compared to wall penetrations. Snow accumulation on roofs can also block the vent.

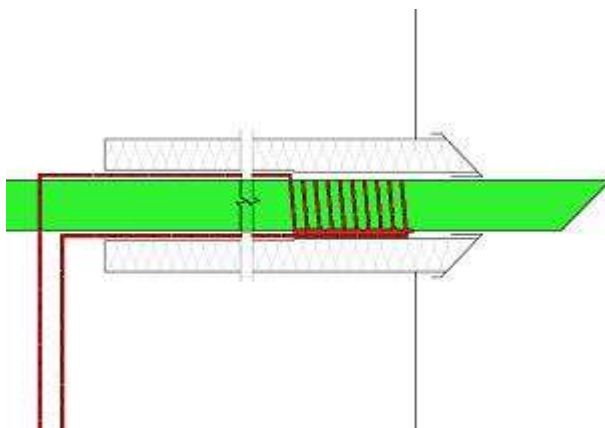

*A plumbing vent penetration through a wall with heat-tracing and insulation*

A plumbing vent penetration through the wall is recommended. It is easier to seal and has a lower risk of leakage.



## TESTING THE PLUMBING SYSTEM

Once the wastewater plumbing is installed, it needs to be tested before being used. An air-pressure or water test can be performed.

The air test involves blocking off all openings in the plumbing system, including the vent pipes, and filling the system with air until a pressure of five psi (35 kPa) is reached. If the air pressure remains stable for 15 minutes without adding any air, the test is a pass.

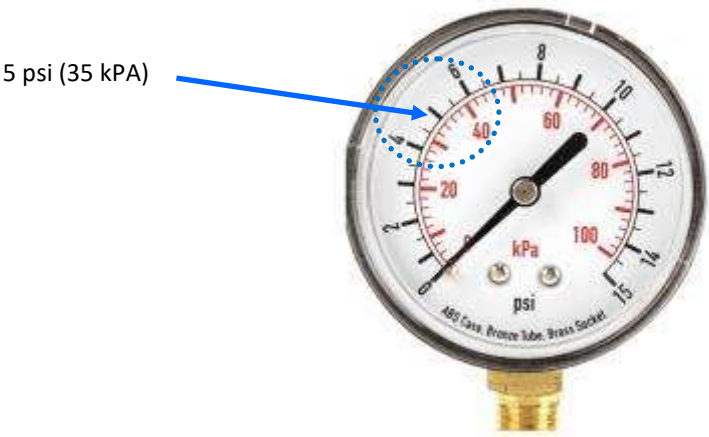

*A pressure gauge showing kPa and psi*

A water test is better suited for testing a section or a component in the plumbing system to limit the amount of water that could leak out. It involves filling the system with water to a level three metres above the components or section being tested. If the water level remains stable for 15 minutes, the test is considered a pass.





## ADDITIONAL RESOURCES

### OTHER RELATED GUIDES

- ***Housing Construction in Nunavik***, Société D’Habitation Du Québec  
([habitation.gouv.qc.ca](http://habitation.gouv.qc.ca))
- ***Good Building Practices Guidelines***, Government of Nunavut  
([www.gov.nu.ca](http://www.gov.nu.ca))

### BUILDING CODES & STANDARDS

- ***National Plumbing Code of Canada***, National Research Council Canada  
([www.nrc.canada.ca](http://www.nrc.canada.ca))
- ***National Building Code of Canada***, National Research Council Canada  
([www.nrc.canada.ca](http://www.nrc.canada.ca))



This technical booklet was developed to help community decision makers and building officers choose among different technical options in the delivery of residential housing for First Nations communities in remote northern Ontario.

## ACKNOWLEDGEMENTS

This guide was funded and commissioned by FNNBOA and the National Research Council of Canada (NRC), and was prepared by Morrison Hershfield Limited. Additional funding was provided by Natural Resources Canada (NRCan), Canada Mortgage and Housing Corporation (CMHC), and Indigenous Services Canada.

Acknowledgement is extended to all those who participated in this project as part of the project team, or as external reviewers, or as representatives from northern communities providing insight into what is needed to make this document useful.

## AUTHORS

Morrison Hershfield Limited

## REVIEWERS & CONTRIBUTORS

Alain Fournier, Founding Partner—EVOQ Architecture (Montreal, QC)

Bruno Di Lenardo, Evaluation Officer—NRC Construction Research Centre (Ottawa, ON)

David T Fortin, Principal Architect/Associate Professor and Director—Laurentian University (Sudbury, ON)

John Kiedrowski, Project Manager—FNNBOA (Ottawa, ON)

Keith Maracle, President—FNNBOA (Shannonville, ON)

Larry Jones, Senior Project Officer—NWT Housing Corp. (Yellowknife, NWT)

Mihailo Mihailovic, Evaluation Officer—NRC Construction Research Centre (Ottawa, ON)