



# BOOKLET 5: FRESHWATER

## TECHNICAL GUIDE FOR NORTHERN HOUSING



TAILORED FOR REMOTE NORTHERN ONTARIO COMMUNITIES





## DISCLAIMER

The information in this publication is based on the most current research available to FNNBOA and has been reviewed by housing industry experts. Readers are advised to evaluate the information, materials and techniques carefully and to consult appropriate professional resources to determine courses of action suitable for their situations. The figures and text are intended as general practice guides only. Project and site-specific factors of climate, cost, geotechnical conditions and architecture must be taken into consideration. Any photographs in this book are for illustration purposes only and may not necessarily represent currently accepted standards. Electronic reproduction of content or this publication is made available for information only and is not an official version of the document. Individuals who download these documents do so at their own risk. FNNBOA will not be responsible for any damage to your computer or any of the information on it.

This document, or any discrete portion of this document (such as a chapter or section) may be reproduced for redistribution, without obtaining the permission of FNNBOA, provided that no changes whatsoever (including translation) are made to the text; that the entire document or discrete part is reproduced; that this copyright notice is included in its entirety in any and all copies of the document or any discrete part of the document; and that no use is made of any part of the document, or the name or logo of the owner of the copyright to endorse or promote any product or service. For any use of this document other than reproduction or for the general reference purposes as set out above, please contact: First Nations National Building Officers Association at [info@fnnboa.ca](mailto:info@fnnboa.ca). For permission, please provide FNNBOA with the following information: Publication's name, year and date of issue.

First Nations National Building Officers Association  
5731 Old Hwy #2, P.O. Box 219  
Shannonville, Ontario K0K 3A0  
[www.fnnboa.ca](http://www.fnnboa.ca)

Tel (613)236-2040  
[info@fnnboa.ca](mailto:info@fnnboa.ca)

1<sup>st</sup> Edition [June 2022]

Provided by FNNBOA under license from the National Research Council of Canada



## The story of freshwater in the north

Only a minority of communities in the north have ground conditions suitable for in-ground water-utility pipes. In southern, urban communities, freshwater is supplied to homes with in-ground water pipes that come from the community's water-treatment plant. Most urban areas are located where there is enough surface soil to install the water pipes deeper than frost penetration.



*Water supply pipes being installed in a trench*



*Above-ground utilidor*

In the north, shallow bedrock, deep frost penetration, high water tables, and permafrost make it very challenging or impractical for most northern communities to use in-ground water-utility pipes. In most cases, above-ground utilidors would be needed to pipe water directly to homes, but utilidors are cost prohibitive for most communities.

As piping freshwater to homes is generally very expensive, water is typically delivered to homes by truck. Houses serviced by water truck require a water holding tank. The water truck fills up at the community's water treatment plant and then fills a water holding tank in each house.



*A water truck being filled at a water treatment plant's fill station*

**This booklet focuses on what freshwater plumbing looks like for a house with a freshwater holding tank filled by a water delivery truck.**



## The Plumbing Skill Trade

The content of this booklet falls within the work of a plumber. Plumbing work includes:

- Connecting any appliances and fixtures that use water (including laundry machines, dishwashers, sinks, showers, tubs, and toilets).
- Layout, assembly, installation, repair, and maintenance of piping for water distribution, waste water and drainage.

Plumbing is regulated by the Ontario College of Trades and Apprenticeship Act. It is a compulsory trade, meaning any one that does plumbing work must be a member of the Ontario College of Trades, which issues certificates of qualification.

The freshwater plumbing system for a residential house falls within Part 9 of the *National Building Code*, which means that the layout and installation of plumbing for a house is normally done entirely by a plumber. A mechanical engineer is typically not involved in plumbing systems for a residential house. Plumbers have years of training and work experience specifically focused on construction that meets the *National Plumbing Code of Canada*.

 **This booklet is best used for planning the freshwater plumbing system when the house design drawings are being created, before a plumber is involved. It is a great resource for initial high-level decision-making, early-stage budget estimating, and planning purposes.**

 **If you are looking to inspect as-constructed plumbing, please refer to the *National Plumbing Code of Canada* or contact a certified plumber.**

Note: The supply of clean, healthy freshwater is best addressed at the community level, with a community water treatment plant that has a truck fill station. Ideally, water is pulled from a well in the ground and then treated. Groundwater usually has less organic life and suspended sediments than surface water. However, groundwater can sometimes be unsuitable due to contaminants that are difficult and very expensive to treat, such as toxic elements from certain types of rock. In this case, water from lakes, rivers, or a reservoir can be easier to properly treat. The design of a community water treatment plant and its water source is beyond the scope of this booklet, and requires professional engineering oversight.



**READ THIS BOOKLET IF YOU NEED TO:**

1. Plan and lay out the freshwater plumbing system for a house in a northern community.
2. Learn more about the factors and considerations that drive decision-making for freshwater plumbing to ensure a *healthy* house.

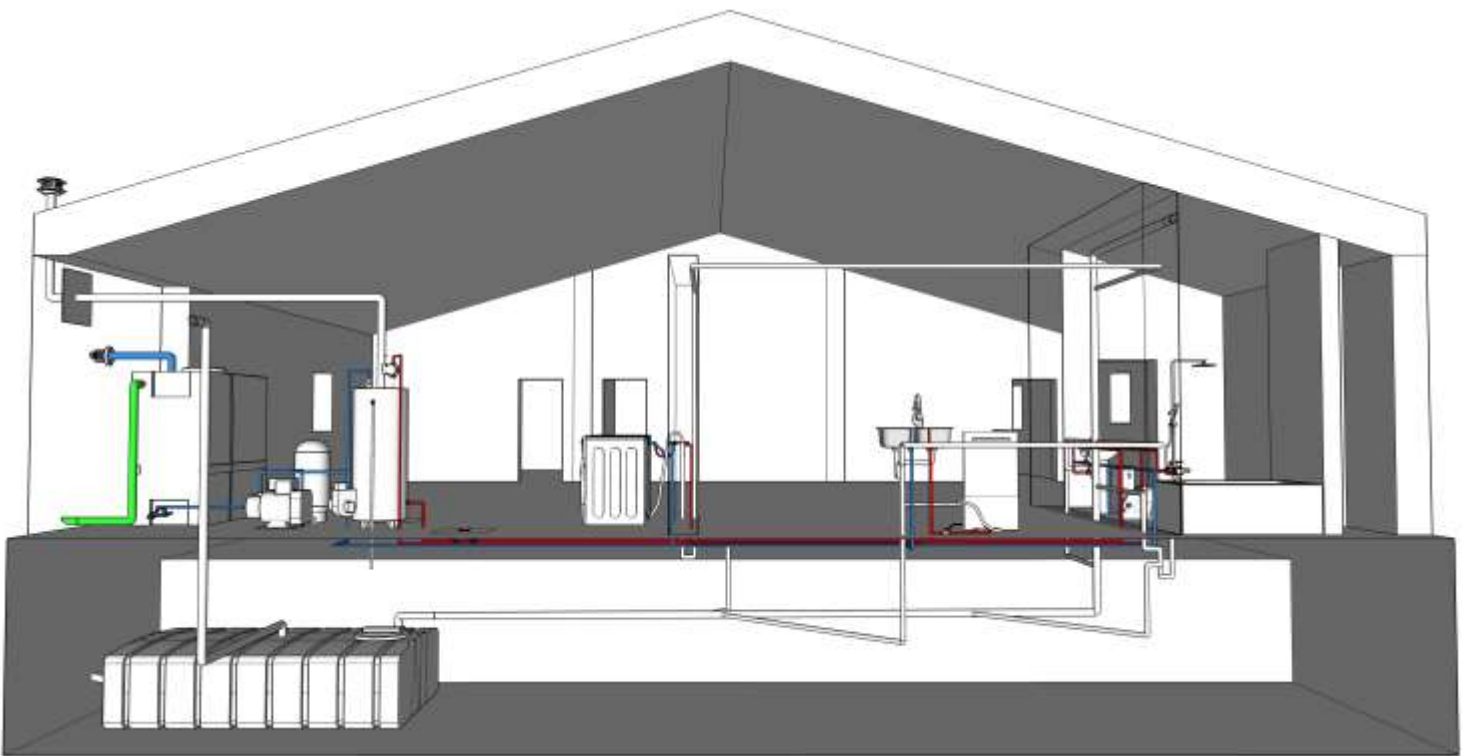

*Healthy—The ultimate goal of this guide is to improve the overall well-being and quality of life for community members, by advising on approaches to freshwater that are well-suited to the north, and construction challenges/constraints, so that homes have a reliable and safe freshwater plumbing system compatible with truck delivery.*



## The Overall Freshwater System

A freshwater-supply plumbing system for a house that relies on truck delivery of water can broadly be summarized as consisting of six general types of components:

- 1) **Fill Port**
- 2) **Water Tank**
- 3) **Pressure Pump and Pressure Tank**
- 4) **Hot Water Tank**
- 5) **Hot and Cold Water Pipes**
- 6) **Fixtures and Appliances**

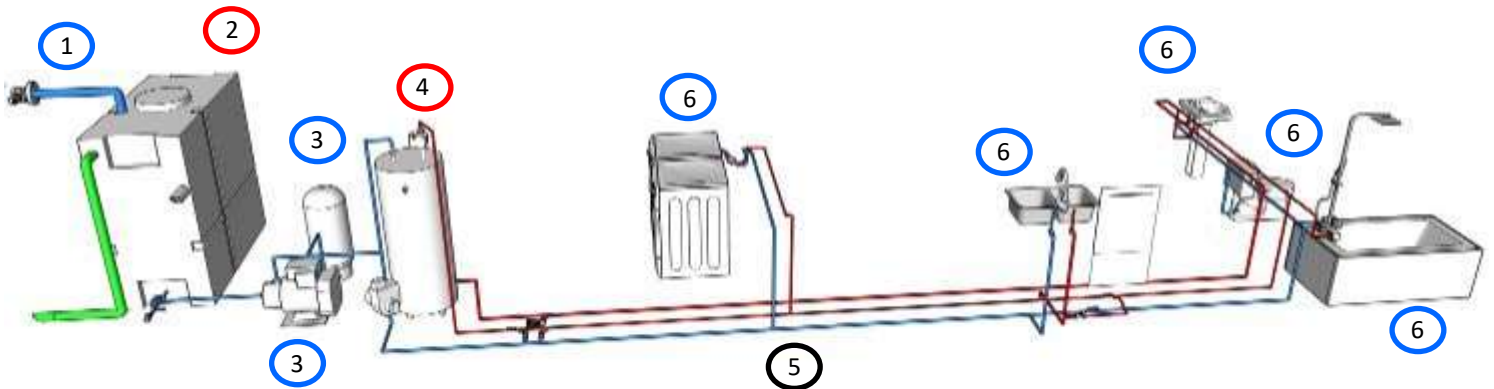



## Freshwater Plumbing System Components

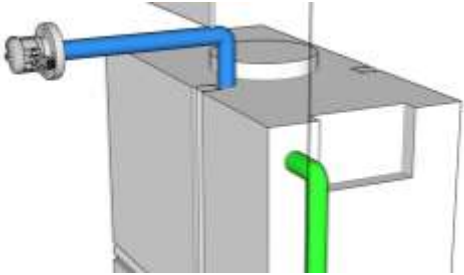

1) **Fill Port** for water truck delivery

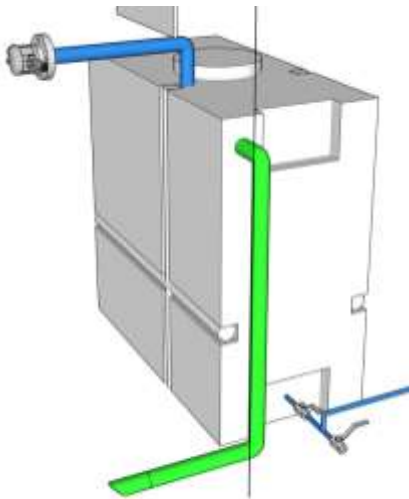

2) **Water Tank** holds all freshwater needed between water truck deliveries

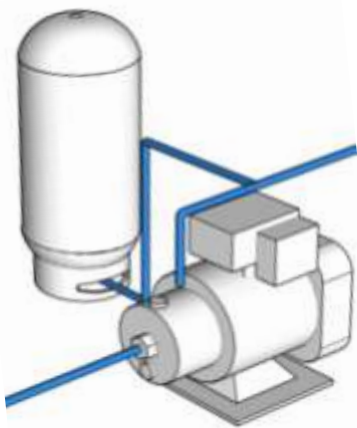

3) **Pressure Pump and Pressure Tank** pressurizes the system to make the water flow



## Continued—Freshwater Plumbing System Components

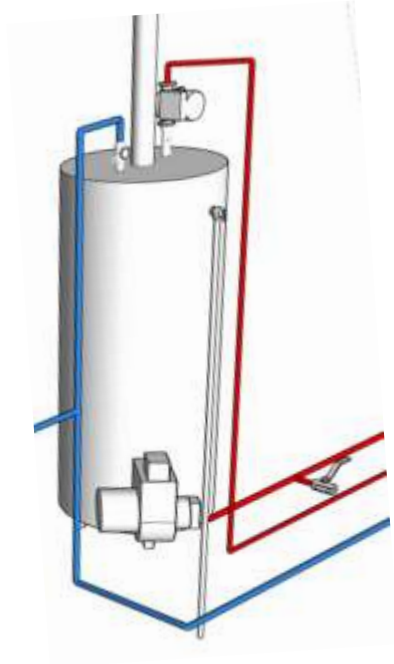

4) **Hot Water Tank** heats and holds hot water



5) **Hot and Cold Water Pipes** direct hot and cold freshwater to water fixtures and appliances

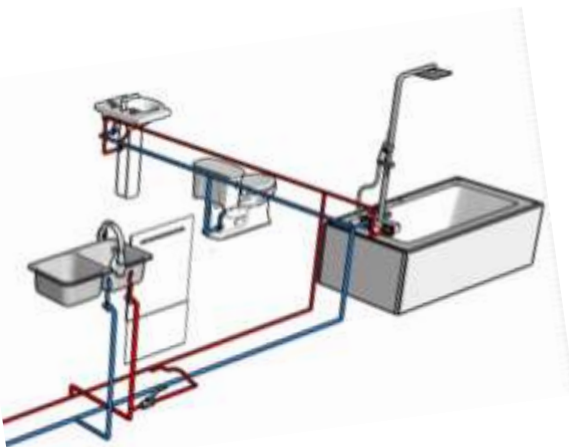

6) **Fixtures and Appliances:** Sink and tub faucets, toilets, showers, dishwashers and laundry washing machines





## Pipe material options

Freshwater piping is commonly referred to as water-supply piping. In the past, galvanized steel pipes were the most common type of pipe, but steel is no longer permitted by the plumbing code for freshwater-supply piping. Copper piping became the most common type of piping, and remained the standard for many years. As modern plastics improved and became readily available, plastic piping started to replace copper. The first main type of plastic piping to be used instead of copper is Polyvinyl Chloride (PVC) and Chlorinated Polyvinyl Chloride (CPVC). Cross-linked polyethylene (PEX) has now become the most common type of piping used for freshwater supply.

The low cost and ease of installing PEX piping has helped it become the dominate type of supply piping. PEX is flexible, and can bend around a corner without a fitting. Fewer fittings means less labour. This flexibility also means the pipe and joints don't need to be installed with as much precision as rigid pipe materials, which require more fittings.

### Cross-linked PolyEthylene (PEX) Pipe:

- Suitable for both hot and cold water
- Low cost
- Flexible: easier to install than rigid pipe
- Comes in easy-to-ship coils
- Red and blue coloured pipe helps identify hot and cold lines.
- Not suitable for long-term sun exposure



PEX pipe in red and blue coils

Note: There are different kinds of PEX pipe. Composite PEX has a layer of aluminum sandwiched between an inside and outside layer of PEX referred to as PEX-AL-PEX; it is used for closed-loop heating systems (e.g. radiant flooring). As PEX-AL-PEX is relatively expensive, there is a lower-cost PEX for closed-loop heating systems that has an oxygen-barrier coating on the outside. The oxygen barrier prevents oxygen from penetrating the pipe and going into the water, which would contribute to corrosion of iron components in the hydronic heating system. In freshwater plumbing for a house, iron components are avoided, so regular non-barrier PEX can be used.

There are also three types of PEX material: A, B, and C. PEX-A involves peroxide in its production and is the most flexible. PEX-B uses a silane moist cure method of cross-linking, and is a bit stiffer than PEX-B, but has higher chlorine resistance and bursting pressure resistance. PEX-C is manufactured using an electronic irradiation method, is the least flexible, and cracks more easily. PEX-C should be avoided. Either PEX-A or PEX-B are recommended.



## Continued—Pipe material options

### Polyethylene (PE) Pipe

- Typically used for outdoor irrigation
- Similar to PEX but only suitable for cold water
- Typically comes in black colour
- Suitable for sun-exposed conditions



*PE pipe coil*

### Polyvinyl Chloride (PVC) Pipe

- Only suitable for cold water
- White in colour
- Rigid
- More fittings and labour to install than PEX
- More expensive than PEX



*PVC pipe is white*

### Chlorinated Polyvinyl Chloride (CPVC) Pipe:

- Similar to PVC but suitable for both hot and cold water
- Comes in an off-white cream colour



*CPVC pipe is cream-coloured*

### Copper Pipe

- More expensive than PEX
- More fittings and labour to install than PEX
- Suitable for both hot and cold water
- Rigid



*Copper pipe*



## Continued—Pipe material options

In summary, common acceptable (safe!) piping materials include the specified potable water grades of:

- Cross-linked Polyethylene (PEX) Pipe
- Polyvinyl Chloride (PVC) Pipe
- Chlorinated Polyvinyl Chloride (CPVC) Pipe
- Copper pipe in thickness classifications K, L, or M (M is thinnest)\*

Note: Drainage Waste and Vent (DWV ) piping is NOT permitted in freshwater supply applications. For example, ABS is not suitable for freshwater, as its use is restricted to DWV. Jointing methods, fittings, and valves must be suitable for the material and in accordance with the *National Plumbing Code (NPC)*.

\*Lead-free solder and fittings are required.

 Although other materials are permitted by code and are safe, regular (non-barrier) PEX pipe type A or B is generally recommended for most freshwater-supply plumbing. Copper and PVC are recommended for specific localized conditions such as at the fill port.



## FILL PORT

for water truck delivery

Fill Port

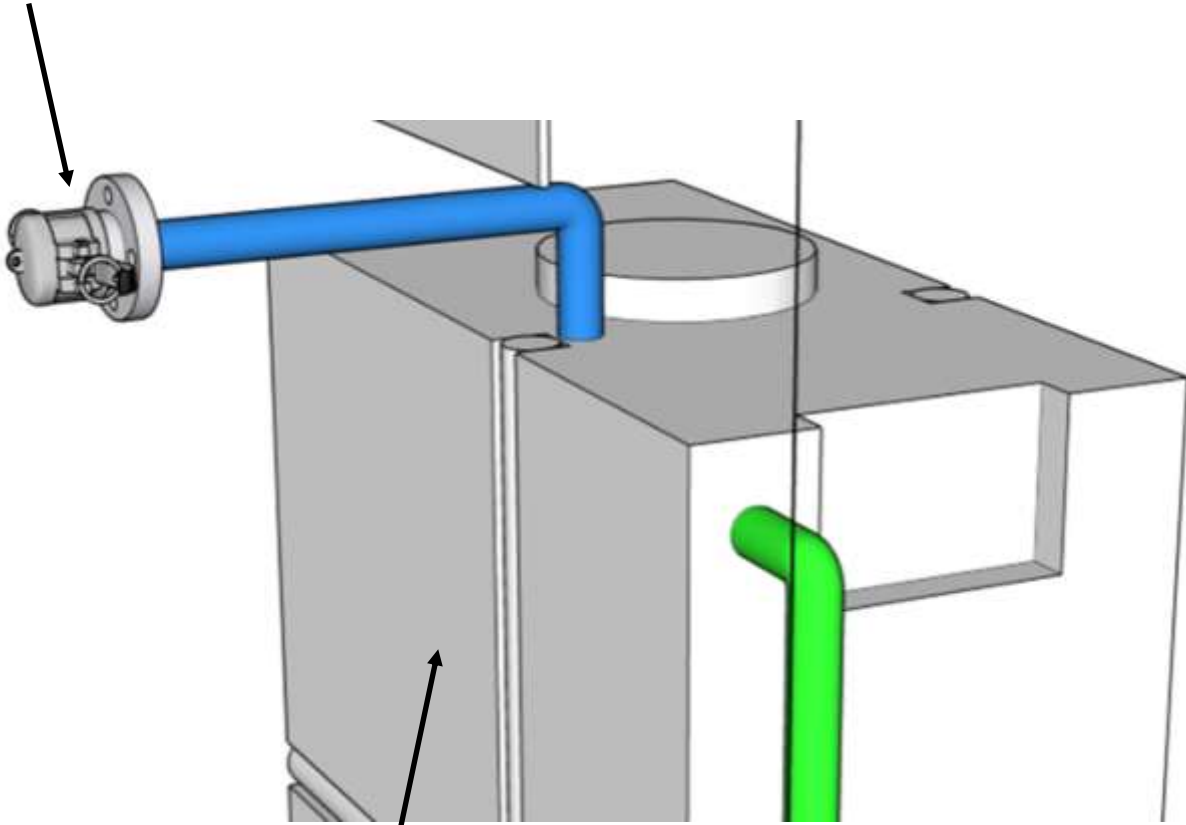

Freshwater Holding Tank



## Fill Port

To avoid risk of wastewater contamination, the fill port should be at least one metre higher and 1.5 metres horizontally, away from the sewage pump-out location. The fill port is usually accessed from an exterior stair landing that provides access to a utility room, as shown in the image below.



*Worker filling up a house's water tank at the fill port with a hose from the water delivery truck*

The fill port pipe should slope toward the tank with a four per cent slope (1/2" drop per foot), so that water does not drip and freeze on the exterior. The fill port connection typically has a 1.5" (38 mm) rapid-connect pipe fitting with a mounting flange to the wall. A camlock fitting is shown as an example below, but the fitting type should be matched with what is used by the community's water delivery truck.

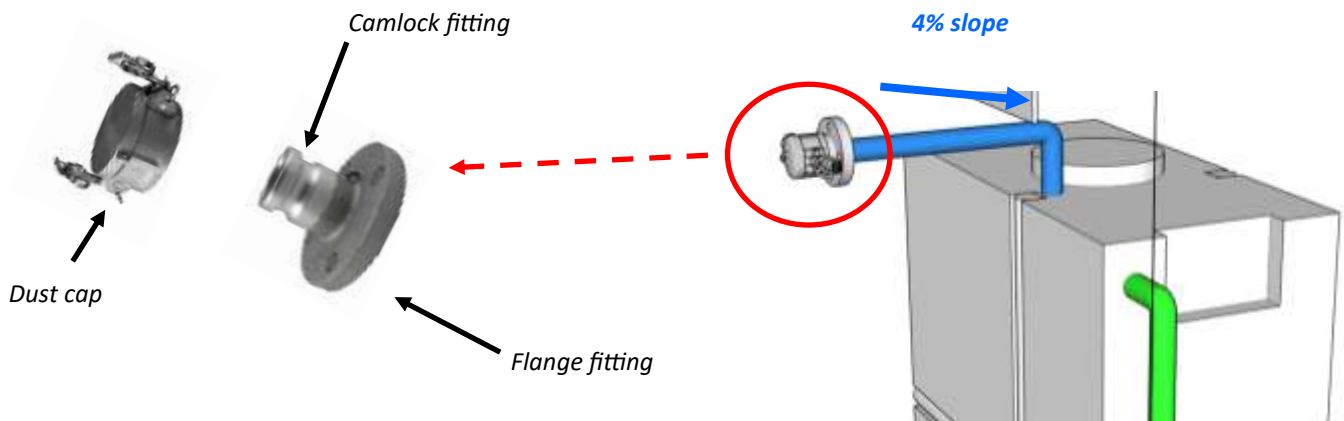

*A rapid-connect fitting for the fill port and its pipe sloping toward the tank at four per cent*



## Continued—The Fill Port

A section of copper pipe should be used where the fill port goes through the wall, for durability and strength. Typical fittings to join the different pipe materials and the tank adaptor fitting are shown below.





## Continued—The Fill Point

The fill point detail is determined by the water supplier—the size and end connection may vary. This could be a simple, capped, open-ended pipe for connecting or inserting a hose, or a mechanical quick-connect coupling. Ensure that a closure (cap) is provided to keep out vermin and dirt when not in use. Confirm requirements with the water supplier.

Provide signage at the fill point to clearly identify that it is a water fill connection.

The fill pipe is typically a 75 mm (three-inch)-diameter standard pipe (could be from 50 to 100 mm in diameter). This pipe is connected to the top of the tank and is sloped to the exterior of the building so that debris and water drains to the outside.

Consider insulating and heat-tracing the outside portion and extending the insulation and vapour barrier 450 mm inside the building, to minimize condensation or frost on the pipe inside the dwelling.

The vent pipe is 75 to 100 mm in diameter and is extended outside the building. Provide a coarse screen to keep out vermin. The outside portion of the vent pipe should be heat-traced and insulated to prevent frost buildup that could block the vent. Extend the insulation and vapour barrier 450 mm inside the building, to minimize condensation or frost on the pipe inside the dwelling. Alternatively, insulate the interior to prevent condensation and frosting. Periodically inspect the vent and remove excess frost and icicles.



## FRESHWATER HOLDING TANK

HDPE

**Building access:** Tanks may need to be installed after the building is constructed or be replaced later in the life of the building. Tanks that fit through doors or pre-built service access openings are desirable. Optionally, consider using multiple smaller tanks to provide the required capacity.

**Tank location inside dwelling:** The tank and related equipment are required to be within a heated space for freeze protection. This may be inside the house or in a service space under or attached to the house.

The structural weight-bearing capacity of the building must be adequate to support the tank without damage to the building.

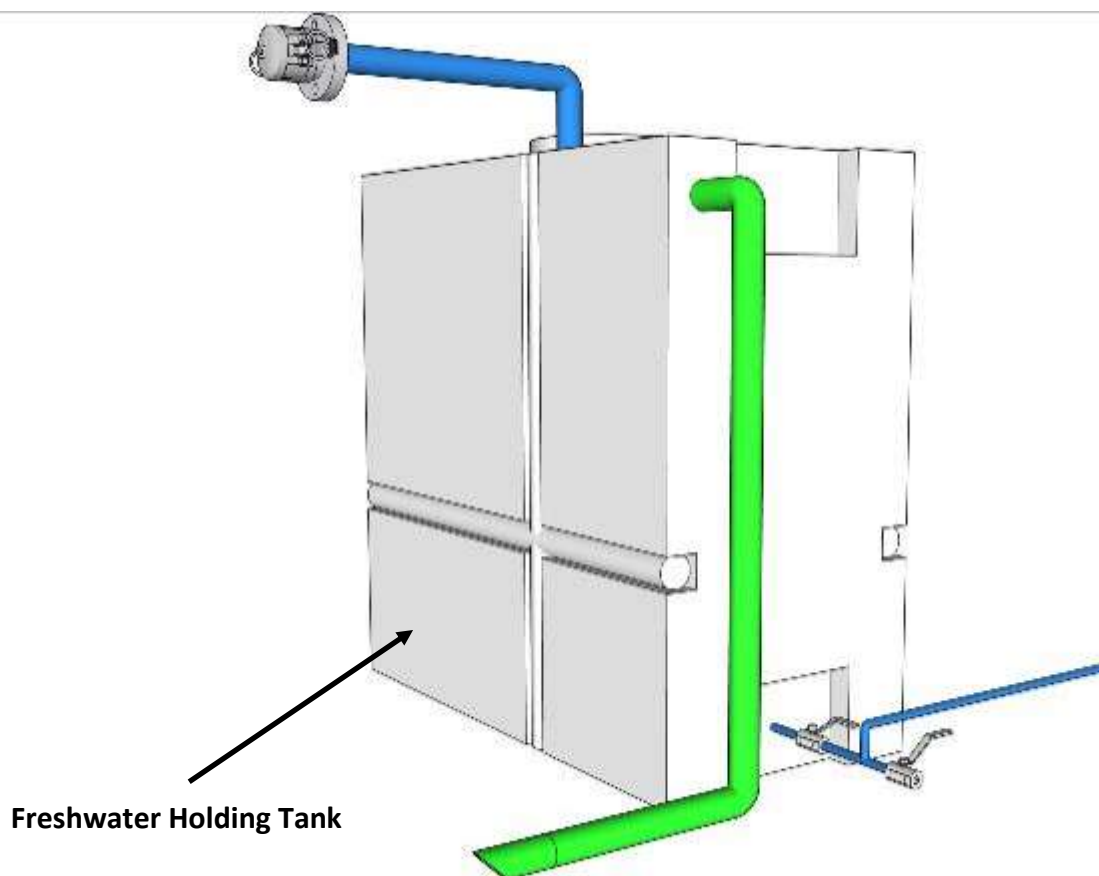





## Freshwater Holding Tank - HDPE

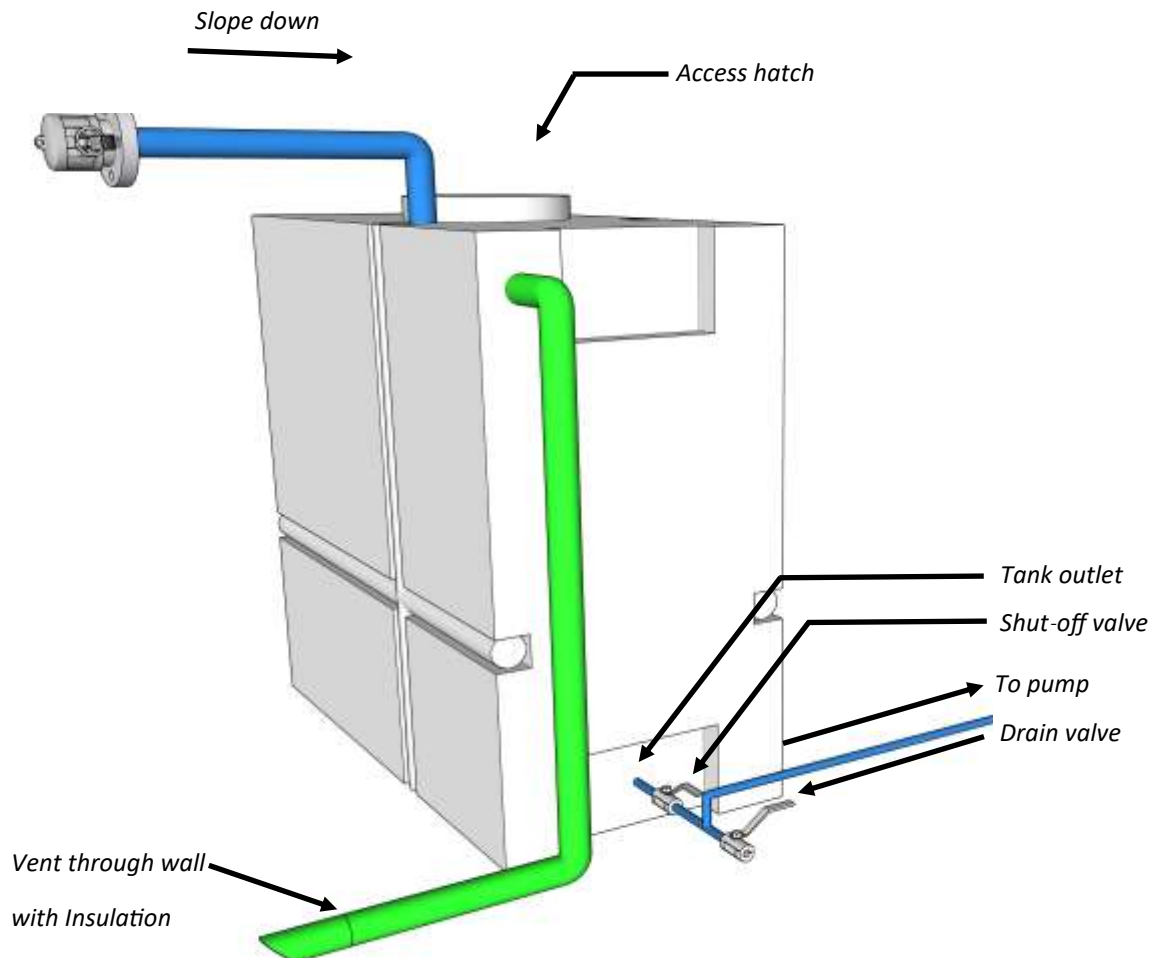

- ⇒ Note that tanks from different manufacturers and different product lines may have additional fittings and connections, depending on the manufacturer and product offering. Select with care to ensure that required connections are provided.
- ⇒ Note that tank connections may be larger in diameter than the described pipe sizes, and that the installer may need to provide adapters to make the connections to the tanks.
- ⇒ Note that the fill point should be installed through the wall away from fuel-system fill point and sewage-tank pump-out.
- ⇒ Note that vent terminations should be installed through the wall instead of the roof to avoid issues with snow buildup on the roof blocking the vent.



## Freshwater Holding Tank - HDPE

Any food-grade water tank may be used for this application. Commonly, tanks for residential applications would be of injection or roto-moulded polyethylene (PE) or high-density polyethylene (HDPE) plastic, or fibreglass. PE and HDPE tanks are lighter than fibreglass, available in many sizes and configurations, less expensive, and easier to transport and install. They are available in many configurations, including cylindrical or rectangular, and in sizes under consideration to fit through doors.

Where standard tanks cannot fit through doors, larger storage volumes can be achieved by installing several smaller tanks in series, with the inlet in the first tank and the outlet in the last tank. Water should flow from the inlet tank (first tank) to the last tank (outlet tank) to prevent water stagnation.



*Different sizes of HDPE tanks*



## Freshwater Holding Tank - HDPE

The cleanout access is a hatch with cover at the top of the tank, to allow for the inspection and cleaning of the tank interior. The cover must be kept in place at all other times, to prevent debris from entering the tank and reduce the risk of children entering the tank. Consider a lockable cover.

The simplest water-outlet connection is typically located near the base at one end of a rectangular tank. This outlet is always provided with a shut-off valve.

Alternatively, a top connection with a drop pipe and foot valve extending to the bottom of the tank could be provided. This has the benefit of reducing the risk of flooding if there is a pipe failure in the system, but adds a level of complexity for maintenance and for draining the tank and piping. It is not recommended.

A drain valve is required between the tank and any other equipment, at a low point. This allows for draining the tank when heat is turned off, or for maintenance and sanitizing the tank. The drain valve should be provided with a hose end connection and cap. The hose-end threaded connection allows installation of a temporary hose to the outside of the building. The threaded cap protects the threaded outlet against damage. A convenient access to the outdoors should be provided.

Optional: provide a “level” gauge to determine remaining water volume. This may not be required with PE tanks, as they are semi-transparent.

Consider installing a drip pan under the tank to collect any drips from slow leaks. Water on floors and against walls may lead to mould and rot, which are hazardous to health and may result in structural failure of the dwelling. Alternatively, provide a waterproof membrane on the floor and partway up the walls.



## Freshwater Holding Tank - HDPE

### Tank Weight:

Consider the weight of the full tank(s) and tank footprint and ensure that the floor structure is adequate to support it. Water is heavy.

Water volume, litres (U.S. gal)	Water weight, kg (lbs)
750 (200)	750 (1655)
1250 (330)	1250 (2755)
2000 (530)	2000 (4400)
2850 (750)	2850 (6280)
3785 (1000)	3785 (8345)



## Freshwater Holding Tank - HDPE

**Also consider the following related items that need to be considered:**

**Reliability of the communal water treatment plant:** If the plant has limited availability, or is unreliable, then more storage capacity might be desirable.

**Frequency of water deliveries:** More frequent deliveries will require smaller tanks, and infrequent or irregular deliveries will require larger tanks.

**Shipping tanks to the dwelling site:** The mode of transportation available may limit the dimensions of the tanks.

**Vehicle access:** A clear route must be provided for the tanker truck deliveries.

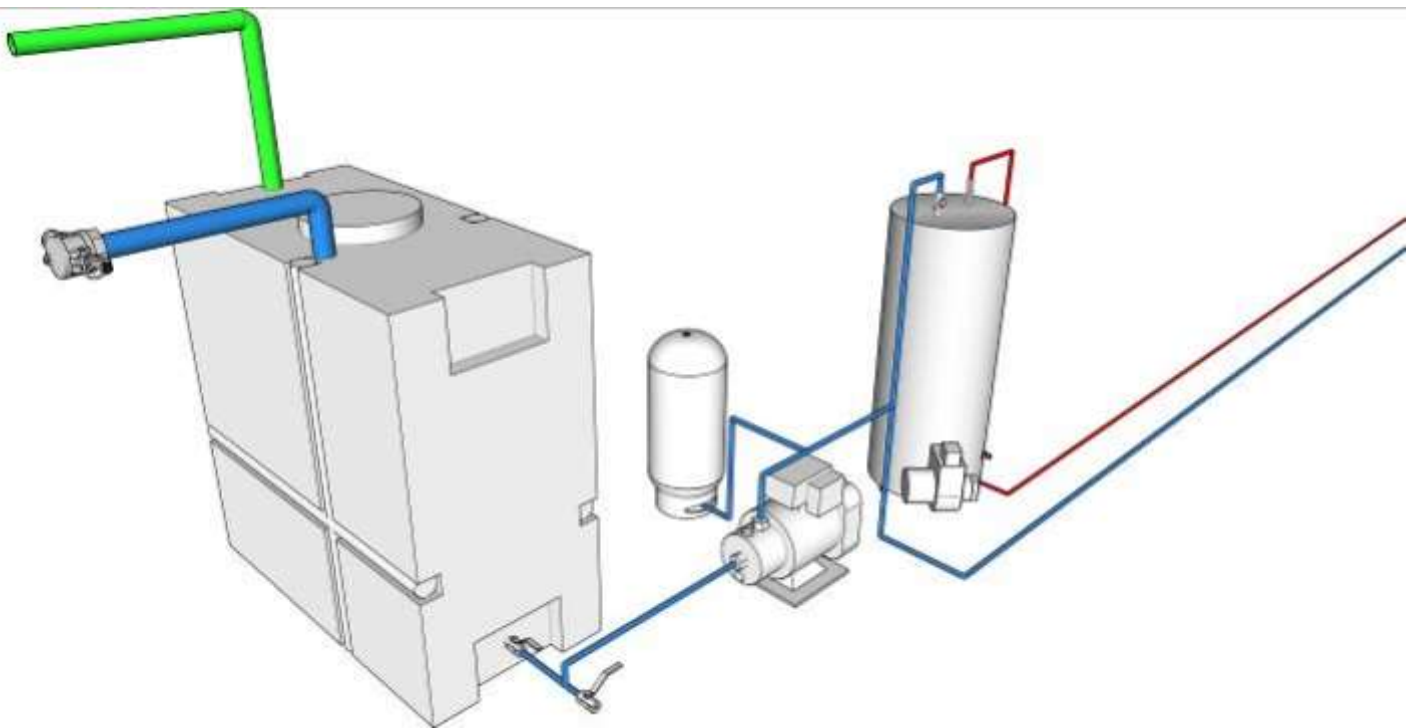



## DISTRIBUTION PUMPS

### Stainless steel or Bronze

Water storage tanks would normally be installed on either the main floor of a dwelling, in a service space below the floor, or in a utility closet accessible from outside the building. The pressure available from the height of water in the tank would be inadequate to supply water to fixtures and appliances at the required pressures. A pressure pump is therefore required to increase the pressure in the distribution system and ensure adequate flows.

Several pump options are available for this application. These include stainless-steel pumps, bronze, or bronze-fitted pumps. They must be suitable for potable water applications.



*Stainless steel pump*



*Bronze or bronze-fitted pump*



## Distribution Pump - Stainless Steel or Bronze

Pumps should be in proximity to storage tanks, at the same general elevation as the base of the tank. If installed higher than tanks, the pump inlet pressure may be inadequate for proper operation, and may require priming after the tanks empty, or after a power failure. If installed much lower than the base of the tank, pumps will not be as convenient to service.

Pump selection would normally consider the design peak flows and pressures. However, pumps selected to meet maximum system demand would be too large, and possibly lead to electrical complications. A pressure tank (described below) can assist in “right-sizing” pumps.

Pumps should be no more than ½ hp (0.373 kW) in size, ideally no more than 1/3 hp (0.25 kW) in this application. Select pumps for one-phase 120/208-volt service, with breakers sized per manufacturer installation guides. Provide a local load-rated disconnect to enable servicing the pump without relying on the electrical panel breakers to isolate power.

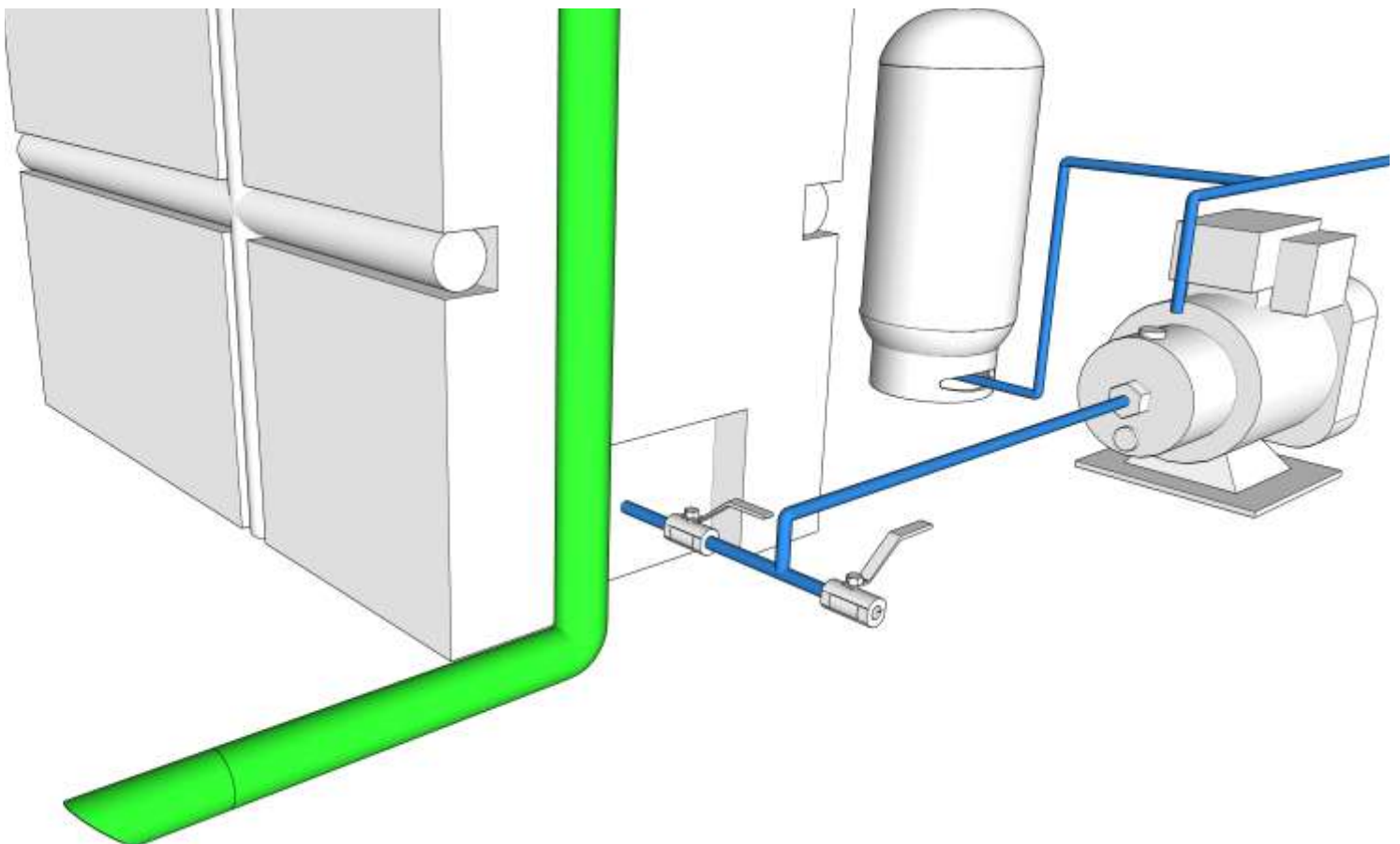



## Distribution Pump - Stainless Steel or Bronze

### Pump control

Pumps are controlled by a pressure switch downstream of the pump. When a fixture is flushed or valve is opened, the water pressure in the system drops. When a preset pressure is reached, the pump turns on. When the plumbing fixture flush cycle is finished or sink valve is closed, the pressure continues to rise until a preset maximum pressure is reached, at which time the pump shuts off.

Typical pressure ranges are 30 pounds per square inch (PSI) for pump “on” to 75 PSI for pump “off.” (In metric, 206 kPa for “on” and 517 kPa for “off.”) This varies depending on the pumps, pressure switches and appliance needs, and corresponds to the normal range of pressures required for proper operation of toilets, dishwashers, and washing machines. Higher pressures are not better, as they may damage appliance components, or overpressure, causing splashing or excessive noise.

### Important Additional Feature

If water is used when the sewage holding tank is full, overflowing the sewage tank may lead to backups and flooding in the dwelling or service space. To prevent overflowing the sewage tank, consider providing an interlock to prevent water pump operation, or closing a valve on the water supply line when a pre-determined high level is reached in the sewage holding tank. Refer to the sewage guide.



*Typical pump fittings with discharge valve (on pump outlet, green handle) pressure switch (black housing) drain valve, pressure gauge to set and verify system pressures, and optional pressure safety valve. The threaded connection at the rear of the assembly is for connecting to a pressure tank. A check valve is also required on the pump outlet before the pressure tank to maintain system pressures.*





## PRESSURE TANKS

### Bladder Pressure Tank

Pressure tanks are used to reduce the frequency of on/off cycles of the pump. If there was no pressure tank, the pump would need to turn on even when only a small amount of water is being used for a short period of time. It would turn on and then off every time a tap is turned on or when a toilet is flushed. This is called short-cycling. Short-cycling is very hard on the electric motor of the pump, and would significantly reduce its service life. The pump in a house without a pressure tank could easily get burned out and require replacement within only a few years. This would be a major inconvenience and increase maintenance/replacement costs.

Including a pressure tank in a freshwater plumbing system avoids short-cycling. It does this by storing a volume of water within the tank at pressure. Water can flow into the system from the tank with minimal change in overall water pressure in the system. This means it is possible to turn on a tap to wash your hands and the pump does not necessarily need to turn on, unless the tap is left running for a long time. The volume of water for washing hands can simply flow out of the pressure tank. Only when the amount of water in the pressure tank drops to the minimum level does the pump need to turn on, to re-fill the pressure tank. As a minimum, the pressure tank should be large enough to store enough water to flush a toilet and wash hands without needing the pump to turn on. A 20-gallon pressure tank is a common pressure tank size that can easily provide enough water to flush a toilet and wash hands.

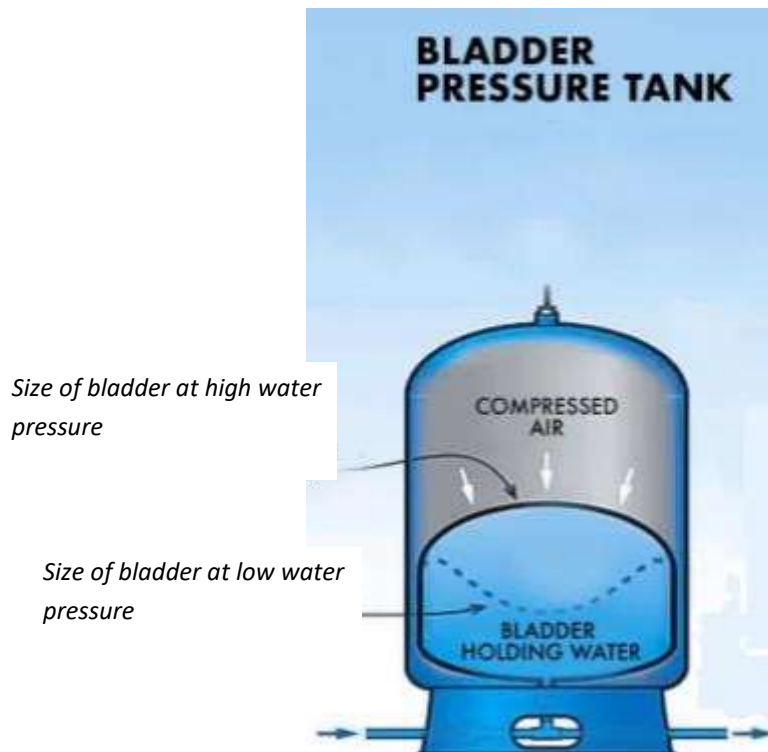



## HOT WATER TANK

Heats and holds hot water

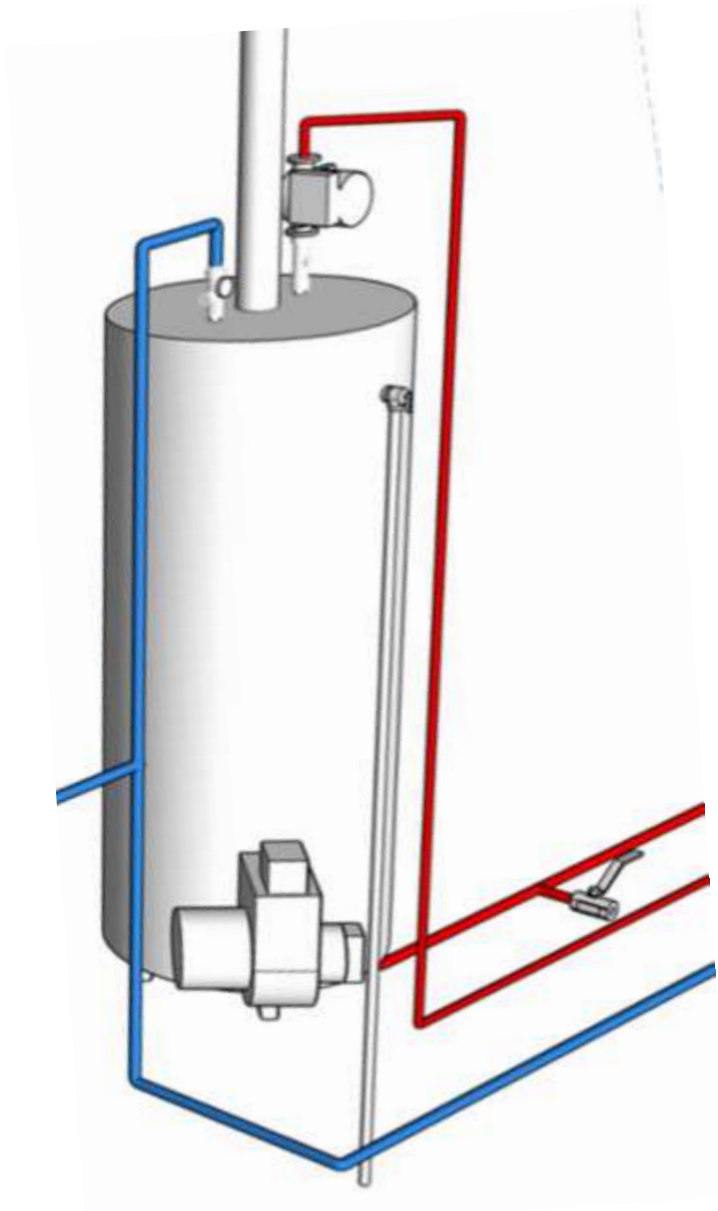

An oil-fired hot-water tank is more efficient than an electric hot-water tank if the electricity in the community is generated at a power plant that burns diesel. Instantaneous hot-water heaters should not be used, to avoid creating large power surges and possible power outages at common times of high water usage (early-morning showers, meals, laundry).



## HOT AND COLD WATER PIPES

### Seasonal Use and Freezing Conditions

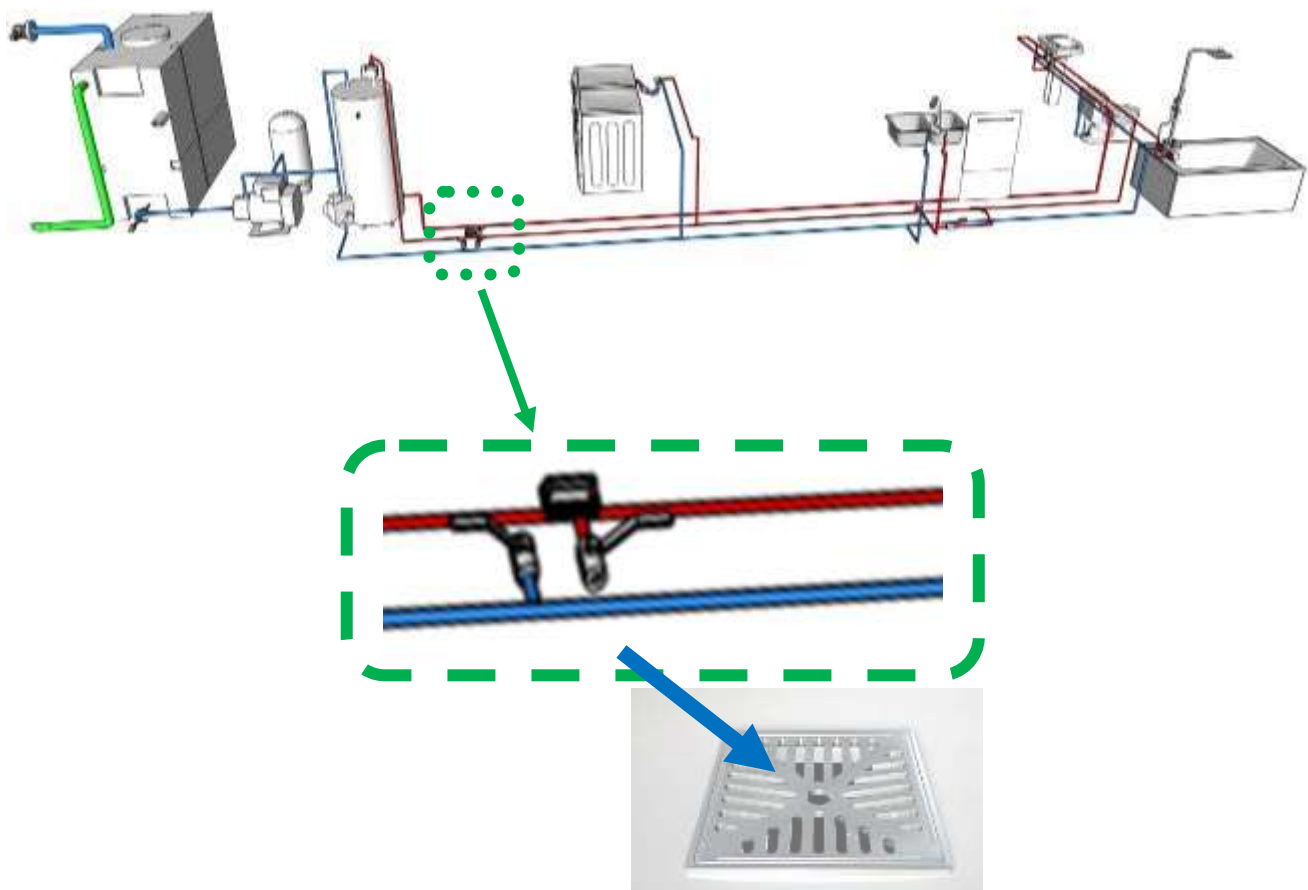

**Water-distribution piping needs valves located over a drain, so that the plumbing can easily be drained for maintenance, or if there is a risk of the plumbing freezing (for example, when the heat is turned off or stops working).**



## Hot and Cold Water Pipes — Seasonal Use and Freezing Conditions

In dwellings used on a seasonal basis, or unoccupied for more than a few days during the winter, there is a significant risk of the heating system being turned off before departure, or failing while occupants are away.

Failure of the heating systems for any reason can lead to the building freezing, which may result in burst piping, damaged equipment, flooding, and damage when the water thaws. Damages from burst piping can be significant, and result in a complete loss of the dwelling, or in less extreme cases, severe water damage and mould growth.

It is recommended that water systems be completely drained to minimize the risk of burst piping and equipment damage whenever the dwelling is unoccupied. During short absences, arrangements should be made to check the house daily, more often in extreme cold weather, to make sure heating systems remain operational.

Provisions for draining the building include:

- Installing all piping in normally heated spaces
- Sloping pipes to low points, without dips or traps, and installing drain valves at low points
- Draining the pump casing (remove plugs) and the expansion tank
- Draining the hot-water tank, fixture traps, and appliances
- Providing drains between the water storage tank and pump
- Draining the water storage tank if away for more than a few days



## FIXTURES AND APPLIANCES

Sink and tub faucets, toilets, showers, dishwashers and washing machines

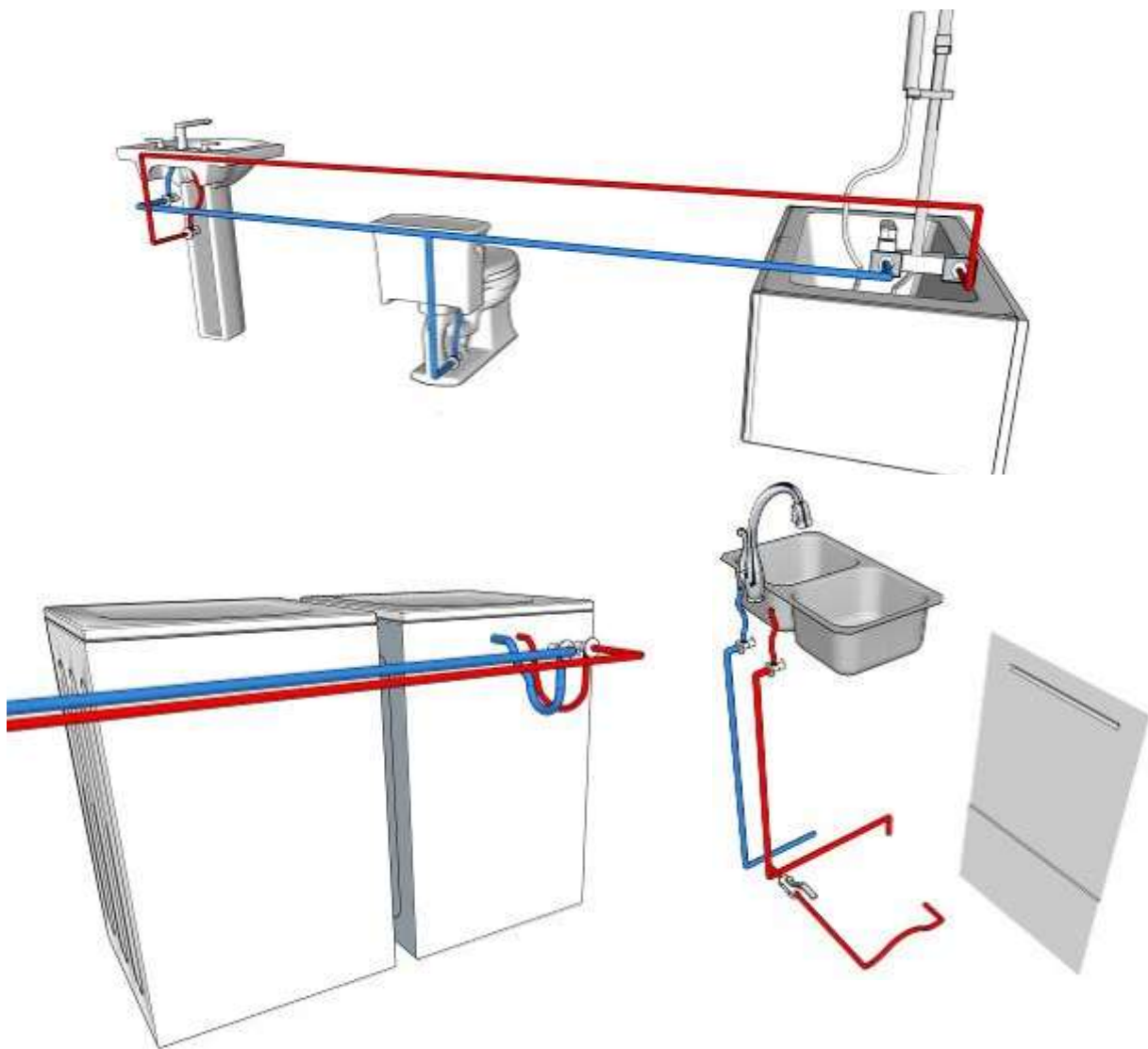



## Fixtures and Appliances

Sink and tub faucets, toilets, showers, dishwashers and washing machines

Low-flow water usage fixtures and appliances are strongly recommended.

Water efficiency will be critical to minimize tank size and increase the time between required water deliveries. Toilets and shower heads have a significant impact on water use.

Toilets are typically the single largest water-using fixture in a house – installing water-efficient toilets will significantly reduce residential water usage.





## Operational and maintenance issues

Care and maintenance of dwelling water systems are required to assure that the potable water supply is safe for its intended uses. The communal treated-water supply must be in accordance with drinking-water guidelines as it leaves the water treatment plant, in transportation, and in delivery to individual end users and residents. Water must be delivered in a safe manner with no contamination between the plant and dwellings. Once delivered, proper operation and maintenance of the system will be required to maintain safe drinking-water quality. The following guidelines are suggested to avoid or minimize the risk of contamination of water supplies:

- Make sure that the fill point and connection are always clean, and that the fill point is capped when not in use.
- Ensure tank access covers are in place to keep out dirt and contaminants.
- Inspect and check the tank vent pipe to ensure it is not blocked by frost and ice and that the inlet screen is in place to reduce the risk of vermin entry.
- Check the water tank on a periodic basis by removing the cleanout cover and looking for debris, unusual colour (for the location), and odours. If any of these are observed, stop using the water until debris is cleared, and the tank is drained and cleaned. Then refill with freshwater.
- Periodically draw samples from the dwelling water supply to verify water quality and safety. This may require professional help from the water purveyor for the community. This is especially important after unusual conditions (see previous item) are observed and corrected.
- Use only potable-water-grade piping, fittings, jointing methods, tanks, pumps, and accessories.



## Operational and maintenance issues

- Use only lead-free products, in accordance with applicable codes and standards, such as those referenced by the *National Plumbing Code*.
- Avoid stagnant water in the tank and system. If water usage is much less than anticipated, or residents are away for long absences, the water in the tank may become stagnant, leading to biological contamination or loss of water quality. Reduce the frequency of water deliveries for low water-use conditions, or drain and refill the tank after long absences. (Proper drain points may be required to easily do this.) Flush water to drain on return to the dwelling, preferably to the ground outside the house, to minimize loading the sewage tank.
- If the communal water supply or tank trucks become contaminated for any reason, stop using the dwelling water supplies for drinking and cooking, and perhaps bathing and laundry, as recommended by the local health authority. Once communal systems are back in operation, and the municipal supply is deemed safe, drain and flush the entire water supply system, including tanks, piping, and fixtures. It may be necessary to disinfect the system before returning to human use.
- Take appropriate precautions to prevent freezing and bursting of piping and components - see suggestions above.





## Note for on-site water treatment

Where there are concerns about safety or quality of the water supply, on-site water treatment can be provided. Correcting communal water-supply problems remains the priority.

Normally, in-house treatment systems are installed downstream of the pressure pump and pressure tanks, and only supply the sinks and lavatories, to keep treatment system sizes to an acceptable cost. They may include all or some of these components:

- A pre-filter, to remove coarse sediments and materials from the water. The pre-filter can filter all the water to the building or be limited to supply the potable-water fixtures only.
- Downstream of the pre-filter serving the drinking-water applications, a final filter (one micron) is usually installed ahead of the following devices.
- A reverse-osmosis filter unit, or
- An ultraviolet disinfection system with UV lamps.
- Water softeners are not usually installed in remote communities due to the need to refresh the salt on a regular basis.

These components can be expensive to install and operate. They require regular maintenance for reliable safe operation, which may be difficult, given the long supply lines and parts availability in the north.

Refer to manufacturer guidelines and approvals for these systems.



## ADDITIONAL RESOURCES

### Handbooks and Design Manuals

- ***Housing Construction in Nunavik***, Société D’Habitation Du Québec  
([habitation.gouv.qc.ca](http://habitation.gouv.qc.ca))
- ***Good Building Practices Guidelines***, Government of Nunavut  
([www.gov.nu.ca](http://www.gov.nu.ca))

### Building Codes

- ***National Plumbing Code of Canada***, National Research Council Canada  
([www.nrc.canada.ca](http://www.nrc.canada.ca))
- ***National Building Code of Canada***, National Research Council Canada  
([www.nrc.canada.ca](http://www.nrc.canada.ca))



This technical booklet was developed to help community decision makers and building officers choose among different technical options in the delivery of residential housing for First Nations communities in remote northern Ontario.

## IMPORTANT NOTE

## ACKNOWLEDGEMENTS

This guide was funded and commissioned by FNNBOA and the National Research Council of Canada (NRC), and was prepared by Morrison Hershfield Limited. Additional funding was provided by Natural Resources Canada (NRCan), Canada Mortgage and Housing Corporation (CMHC), and Indigenous Services Canada.

Acknowledgement is extended to all those who participated in this project as part of the project team, or as external reviewers, or as representatives from northern communities providing insight into what is needed to make this document useful.

## AUTHORS

Morrison Hershfield Limited

## REVIEWERS & CONTRIBUTORS

**Alain Fournier**, Founding Partner—EVOQ Architecture (Montreal, QC)

Bruno Di Lenardo, Evaluation Officer—NRC Construction Research Centre (Ottawa, ON)

**David T Fortin**, Principal Architect/Associate Professor and Director—Laurentian University (Sudbury, ON)

John Kiedrowski, Project Manager—FNNBOA (Ottawa, ON)

Keith Maracle, President—FNNBOA (Shannonville, ON)

**Larry Jones**, Senior Project Officer—NWT Housing Corp. (Yellowknife, NWT)

Mihailo Mihailovic, Evaluation Officer—NRC Construction Research Centre (Ottawa, ON)